



# FPT-35T-110VAC SUBMITTAL

## Dual Temperature Alarm with Heater Control FIRE PROTECTION TANK CONTROL W/ ALARMS

**NEW MORE RELIABLE TECHNOLOGY** by Waterline Controls® FOR SPECIFYING ENGINEERS WITH A TESTED & PROVEN TRACK RECORD in MRO APPLICATIONS for 10+ years.

Our controls can **REPLACE ALL SENSOR & CONTROL TYPES** in ALL water based applications.

We **ARE NOT** similar to float switches, capacitive, conductive, ultrasonic, or pressure transducers. We **ARE** more reliable, easy to operate, & last longer.



### Features:

- 5 Year Limited Warranty
- NEMA 4x control enclosure
- Intuitive LED indicators
- Dry contact connections for BMS, BAS, or fire panel
- Fully automated by microprocessor
- Color coded sensor rods & wires for intuitive installation
- Test Push-button for output devices
- Power relays for valves, pumps, etc.
- Optional temperature sensor controlled relay
- Controls can be mounted in equipment room w/ sensor wired remotely
- Push-button for relay test
- Modular construction
- Extendable sensor probes

### Benefits:

- Permanently eliminate float switches
- Less than 1% failure rate in the field
- Intrinsically safe - no high voltage in water
- Never needs recalibration
- Fully Commercialized
- Sensor will not plate, foul, or deteriorate
- Water quality does not matter
- Flexibility in design to meet any scenario
- Minimal maintenance
- Stand-alone controls
- Only moving parts are replaceable relays

Phone: 480-905-1892  
www.waterlinecontrols.com  
Email: info@waterlinecontrols.com

# FPT-35T-110VAC SUBMITTAL

## Dual Temperature Alarm with Heater Control FIRE PROTECTION TANK CONTROL W/ ALARMS

### FUNCTIONAL DIAGRAMS

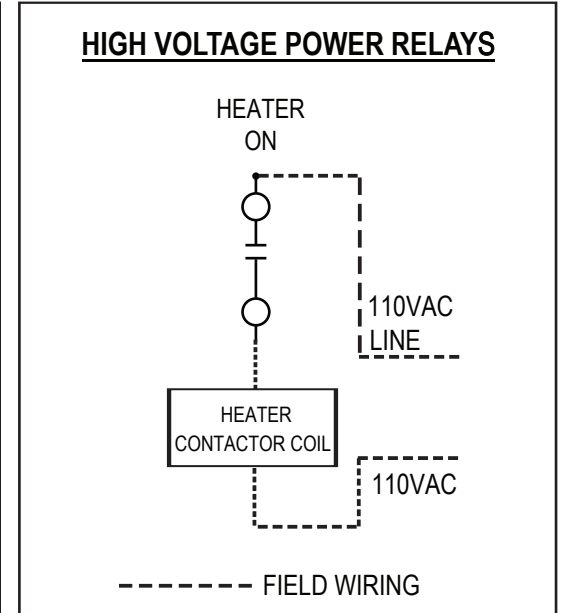
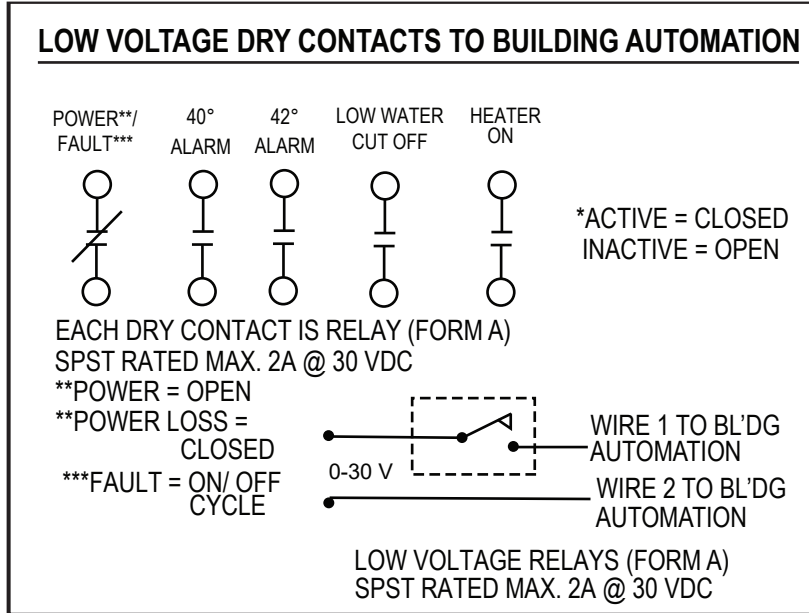
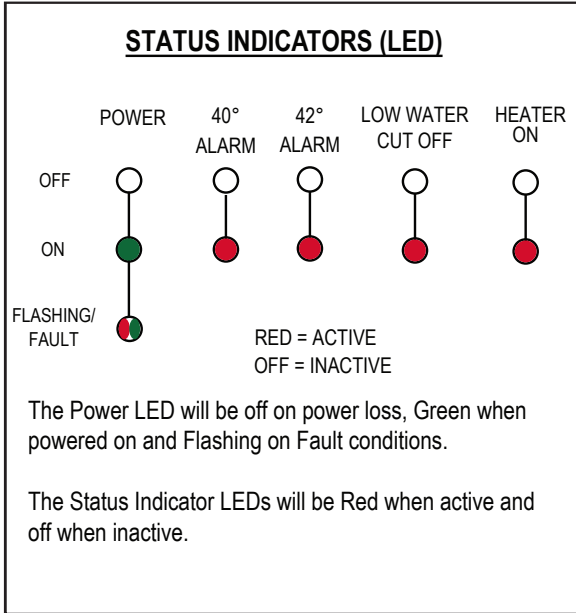

### PRODUCT FUNCTION TRUTH TABLE

MODEL	BMS DRY CONTACTS						POWER RELAY				SELF TEST
	FAULT/ POWER LOSS	40° ALARM	42° ALARM	LOW WATER CUTOFF	HEATER ON	BAS WIRES	HEATER ON				
FPT-35T	X	X	X	X	X	10	X				X

Phone: 480-905-1892  
www.waterlinecontrols.com  
Email: info@waterlinecontrols.com

# FPT-35T-110VAC SUBMITTAL

## Dual Temperature Alarm with Heater Control FIRE PROTECTION TANK CONTROL W/ ALARMS

### PHYSICAL CONNECTIONS

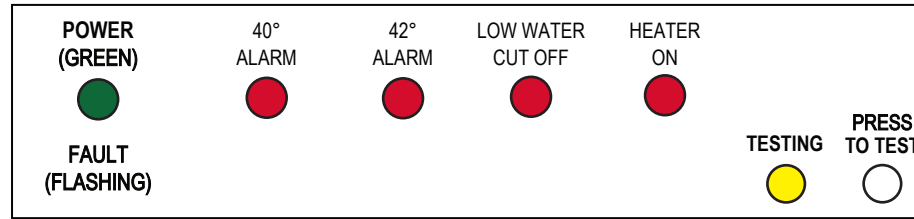
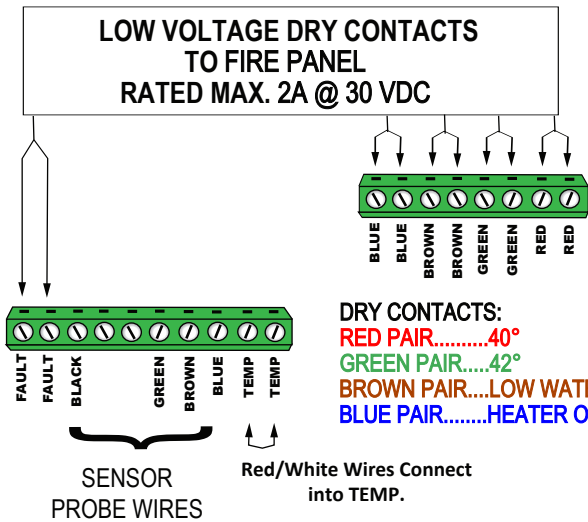

CONTROL UNIT RATINGS	
VOLTS:	110 VAC (50/60 HZ)
AMPS:	0.5 AMPS
WATTS:	55W
220VAC ALSO AVAILABLE	

**NOTE:** The Red and White sensor wires plug into either of the TEMP connections.  
 Do not use the terminal connections labeled Red or White.

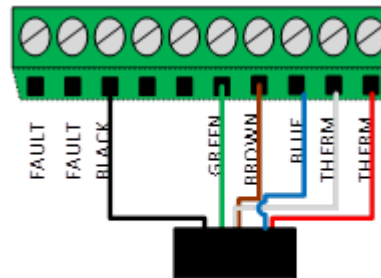
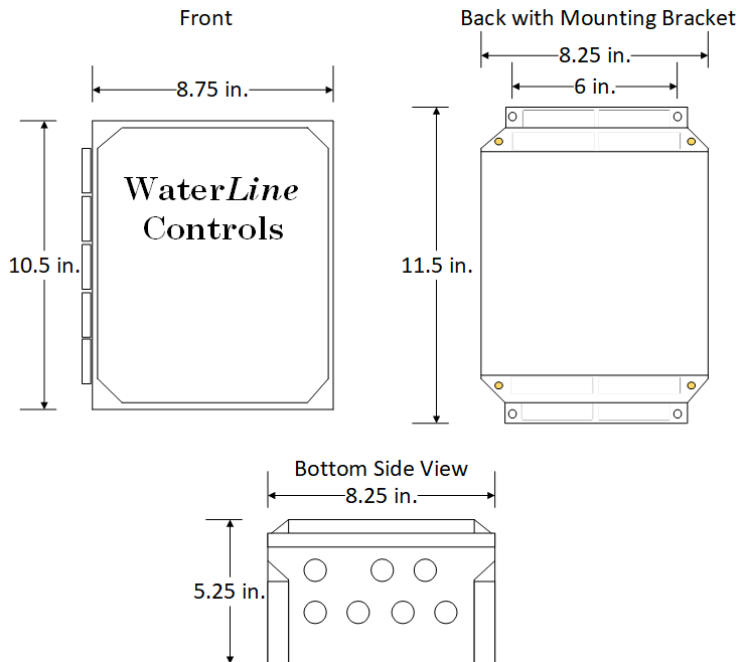

Connect Black /Green/Brown/Blue wires to respective inputs.  
 Connect Red/White wires to THERM inputs.

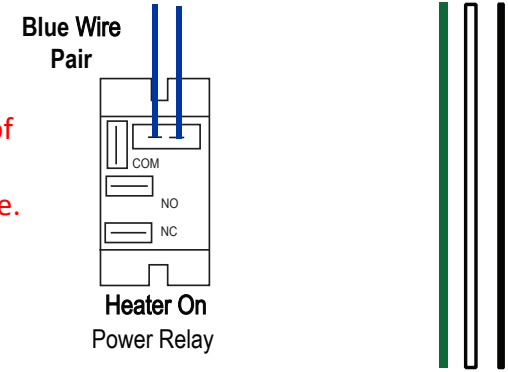

#### HIGH VOLTAGE POWER RELAYS

Form C - SPDT  
 Rated max.: 120 VAC @ 40A  
 All relays are typical  
 All relay terminals are 1/4" male spade

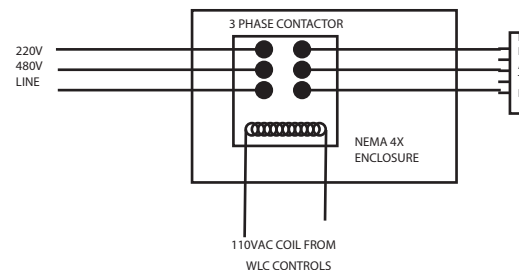

Phone: 480-905-1892  
[www.waterlinecontrols.com](http://www.waterlinecontrols.com)  
 Email: [info@waterlinecontrols.com](mailto:info@waterlinecontrols.com)

# FPT-35T-110VAC SUBMITTAL

## Dual Temperature Alarm with Heater Control FIRE PROTECTION TANK CONTROL W/ ALARMS

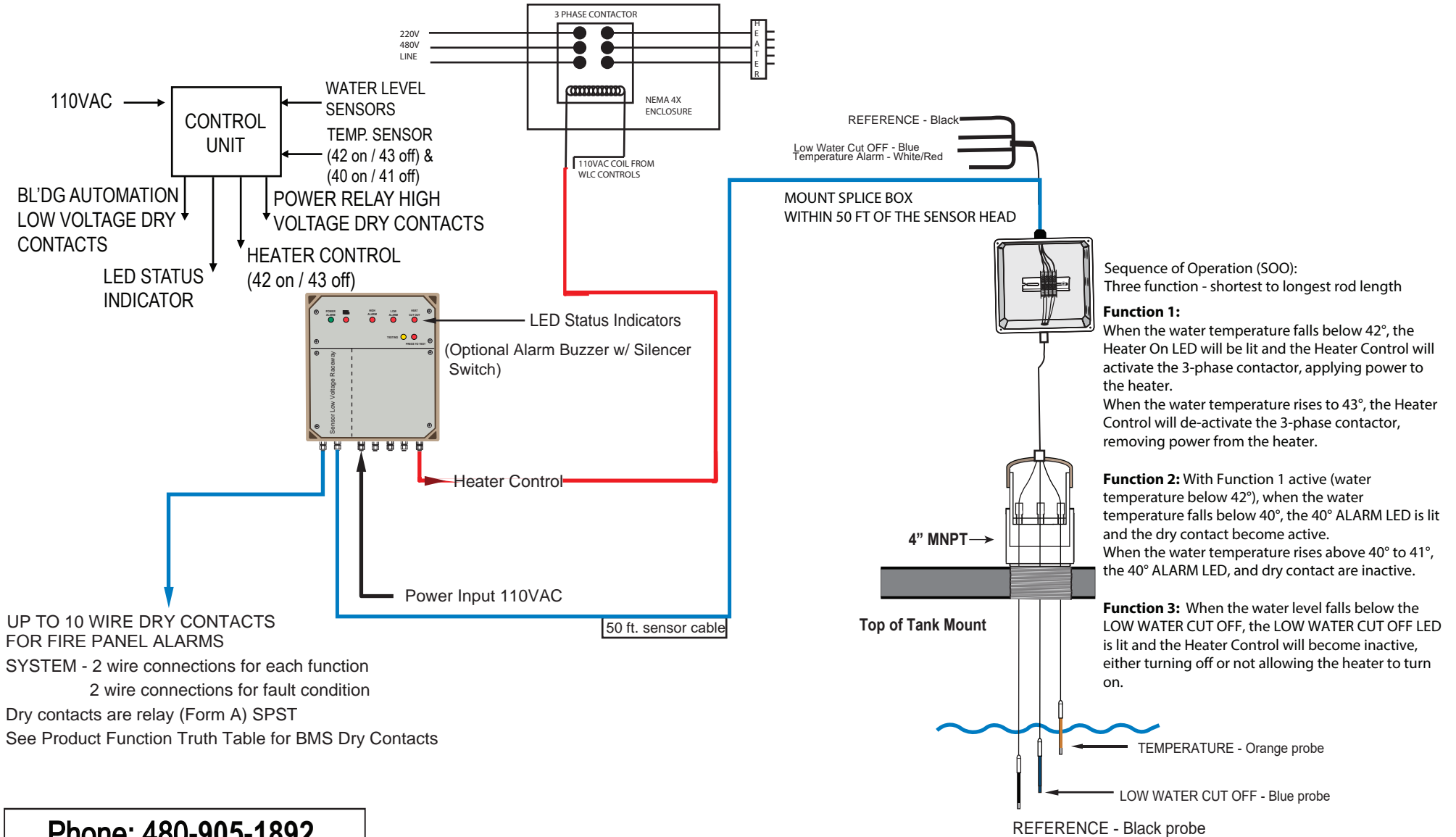

UP TO 10 WIRE DRY CONTACTS FOR FIRE PANEL ALARMS  
SYSTEM - 2 wire connections for each function  
2 wire connections for fault condition  
Dry contacts are relay (Form A) SPST  
See Product Function Truth Table for BMS Dry Contacts

**Phone: 480-905-1892**  
**www.waterlinecontrols.com**  
**Email: info@waterlinecontrols.com**

# Electronic Water Level Management Systems

## 5 Year Limited Warranty - *WaterLine* Controls®

The 5 Year Limited Warranty is extended to the original consumer purchaser of this *WaterLine* Controls manufactured by *WaterLine* Controls, Scottsdale, Arizona. *WaterLine* Controls warrants the unit, including the parts and components thereof, to be free of defects in material and workmanship under normal use and service conditions. This warranty does not cover plumbing or normal replacement items and parts, including gaskets and O-rings. *WaterLine* Controls does not cover improper installation of the unit or its parts. If you have any questions regarding the installation of your *WaterLine* Controls unit, please feel free to contact us. Be sure to include the serial number of your unit.

The 5 Year Limited Warranty commences on the date of installation. Parts discovered to have manufacturing defects within 1 Year of installation shall be replaced at no charge to the original consumer. Defects discovered after one year and up to the fifth year following the installation, shall be replaced at a fee of \$275.00 per item. *WaterLine* Controls will repair or replace, at its option, a unit or part proved to be defective within the warranty period and under the conditions of this 5 Year Limited Warranty.

This 5 Year Limited Warranty does not apply if the failure is caused or contributed by any of the following: power surges, acts of God, power failure or reduction of power supplied to the unit, unusual atmospheric conditions, improper handling, improper storage, winter freezing, abuse, improper installation, unsuitable application, lack of reasonable and necessary maintenance, natural disasters, or repairs/alterations made or attempted by other than *WaterLine* Controls or an Authorized Technician approved by *WaterLine* Controls.

The consumer must deliver or ship the unit or warranty parts freight prepaid to *WaterLine* Controls. Authorization to return an item to *WaterLine* Controls must be obtained from *WaterLine* Controls Customer Service Department at 480-905-1892. For further assistance with this process please contact the Customer Service Department. Be sure you insure your shipment against loss or damage in transit.

*WaterLine* Controls is not responsible for the cost of removal of the unit or parts of the unit, damages due to removal, or any other expenses incurred, including in shipping the unit or parts to or from *WaterLine* Controls or its closest Authorized Service Center or the installation of the repaired or replaced unit. The consumer must bear these expenses.

THIS 5 YEAR LIMITED WARRANTY IS IN LIEU OF ALL OTHER WARRANTIES, EXPRESSED OR IMPLIED, INCLUDING THE IMPLIED WARRANTIES OF MERCHANTABILITY AND FITNESS FOR A PARTICULAR PURPOSE AND ALL SUCH OTHER WARRANTIES ARE DISCLAIMED EXCEPT TO THE EXTENT ANY IMPLIED WARRANTY MAY BE IMPOSED BY STATE CONSUMER LAW. ANY SUCH IMPLIED WARRANTY IMPOSED BY STATE CONSUMER LAW IS LIMITED IN DURATION TO ONE (1) YEAR FROM THE DATE OF INSTALLATION. IN NO EVENT SHALL *WATERLINE* CONTROLS BE LIABLE FOR INCIDENTAL OR CONSEQUENTIAL DAMAGES OR ANY NATURE OR KIND OR FOR DAMAGES TO PERSONS OR PROPERTY, INCLUDING ANY DAMAGE RESULTING FROM THE USE OF THE UNIT WITH A SUBSTANDARD WATER CIRCULATION OR SUPPLY SYSTEM.

Some states do not allow limitations on how long an implied warranty lasts, or the exclusion or limitation of incidental or consequential damages, so the above limitations may not apply to you.

This limited warranty is valid only in the United States of America and Canada.

*WaterLine* Controls • PO Box 12544 Scottsdale • Arizona 85267

Phone: 480-905-1892 Email: [info@waterlinecontrols.com](mailto:info@waterlinecontrols.com)

© SDI 2024