



WLC-6450D-110VAC SUBMITTAL

Duplex Fill (Alternating On, All Off) w/ Low & High Alarms

NEW MORE RELIABLE TECHNOLOGY by Waterline Controls® FOR SPECIFYING ENGINEERS WITH A TESTED & PROVEN TRACK RECORD in MRO APPLICATIONS for 10+ years.

Our controls can REPLACE ALL SENSOR & CONTROL TYPES in ALL water based applications.

We ARE NOT similar to float switches, capacitive, conductive, ultrasonic, or pressure transducers. We ARE more reliable, easy to operate, & last longer.



Features:

- 5 Year Limited Warranty
- NEMA 4x control enclosure
- Intuitive LED indicators
- Dry contact connections for BMS, BAS, or fire panel
- Fully automated by microprocessor
- Color coded sensor rods & wires for intuitive installation
- Test Push-button for output devices
- Power relays for valves, pumps, etc.
- Optional temperature sensor controlled relay
- Controls can be mounted in equipment room w/ sensor wired remotely
- Push-button for relay test
- Modular construction
- Extendable sensor probes

Benefits:

- Permanently eliminate float switches
- Less than 1% failure rate in the field
- Intrinsically safe - no high voltage in water
- Never needs recalibration
- Fully Commercialized
- Sensor will not plate, foul, or deteriorate
- Water quality does not matter
- Flexibility in design to meet any scenario
- Minimal maintenance
- Stand-alone controls
- Only moving parts are replaceable relays

Sensor and Control Panel Pre-Installation Planning Guidelines

Sensor and Control Panel Considerations

- Use the metal of the cooling tower as a barrier from EMF interference (radar, cell, antenna or radio towers).
- Do NOT use the same power source or ground circuit of a VFD.
- Do NOT run the sensor cable parallel to VFD control wires or high voltage lines.
- If the control panel and/or sensor cannot be out of site of a VFD, then maintain at least 15 feet from VFD panels, wires.

Rules for High and Low voltage circuits

- Maintain at least 3" spacing between the sensor cable and high voltage lines.
- Do NOT run the sensor cable in the same conduit with high voltage lines.
- When crossing high voltage lines, cross them perpendicularly.
- Do NOT coil excess sensor cable.

Sensor Cable Length

- The sensor cable comes in 50-foot increments, starting at 50ft. Order the cable longer than you need it. The sensor cable should be cut to fit. Be sure to leave enough slack (1 ½ times the length of the longest rod) in the sensor cable in the event the sensor needs to be removed for maintenance or inspection. If a sensor cable splice is necessary, contact Waterline Controls to order a splice box enclosure.
- Install the sensor cable in earth grounded metal conduit separate from the earth grounded metal electrical conduit housing high voltage lines. In those cases where running separate conduit is not plausible then follow the rules for high and low voltage circuits. Do NOT zip tie the sensor cable to conduit carrying high voltage lines.

Control Panel

- Provide a dedicated 15 to 20-Amp circuit to the control panel. Do NOT share the ground or neutral with other circuits and by no means should the circuit for a VFD be used.
- We recommend placing the control panel as close to the cooling tower as possible keeping it above the water basin and out of sight of any Variable Frequency Drives (VFD).
- The control panel should be mounted in a convenient location where water spray will not impinge upon the unit and at a height above the tank overflow level to prevent water from feeding into the sensor wire conduit.
- Plan to mount the control panel where the low voltage wire crosses (perpendicularly) the least number of high voltage circuits.

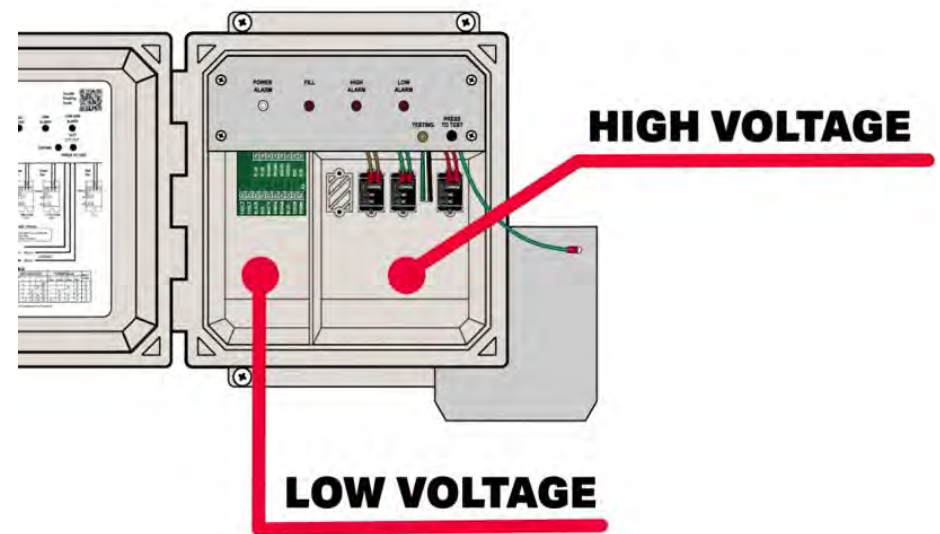

Phone: 480-905-1892
www.waterlinecontrols.com
 Email: info@waterlinecontrols.com

WLC-6450D-110VAC SUBMITTAL

Duplex Fill (Alternating On, All Off) w/ Low & High Alarms

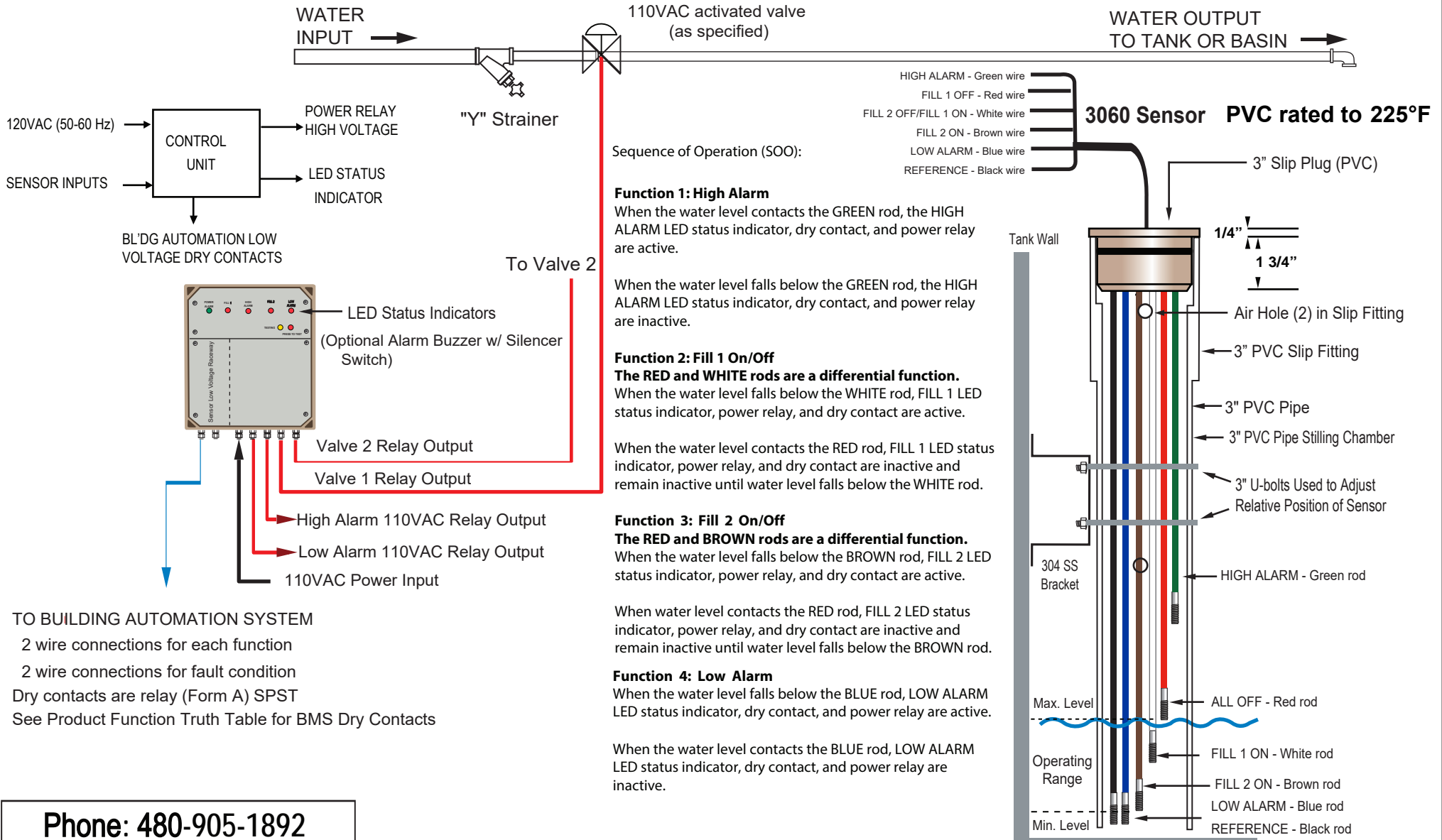

TO BUILDING AUTOMATION SYSTEM
 2 wire connections for each function
 2 wire connections for fault condition
 Dry contacts are relay (Form A) SPST
 See Product Function Truth Table for BMS Dry Contacts

Phone: 480-905-1892
www.waterlinecontrols.com
Email: info@waterlinecontrols.com

Sensor shown with Side Wall Mount. Other mounting options are available.
 3" PVC pipe of length greater than or equal to length of longest rod. Adjust by moving 3" PVC Pipe upward/ downward, then tighten U-bolt.

WLC-6450D-110VAC SUBMITTAL

Duplex Fill (Alternating On, All Off) w/ Low & High Alarms

PHYSICAL WIRING CONNECTIONS

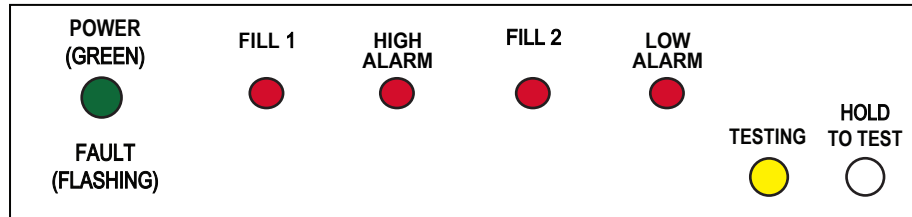
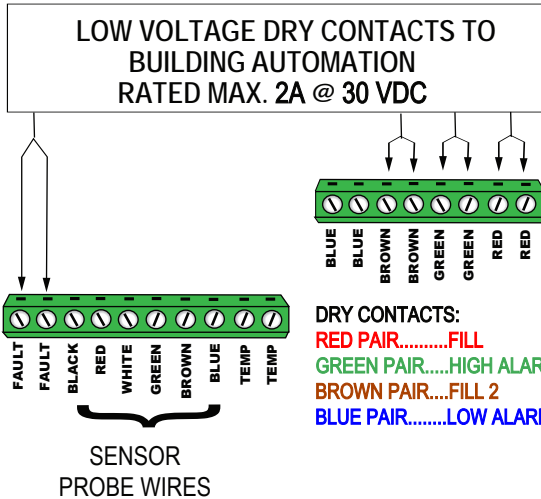

CONTROL UNIT RATINGS	
VOLTS:	110 VAC (50/60 HZ)
AMPS:	0.5 AMPS
WATTS:	55W
220VAC ALSO AVAILABLE	

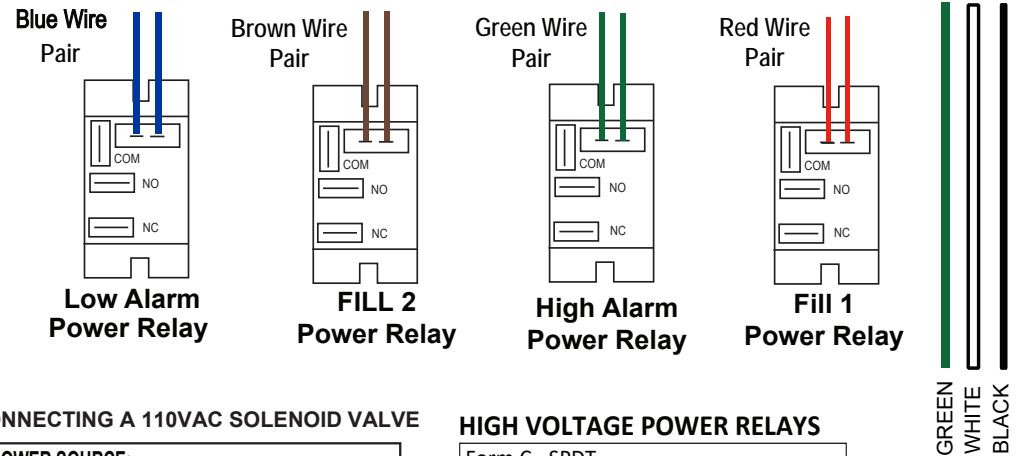
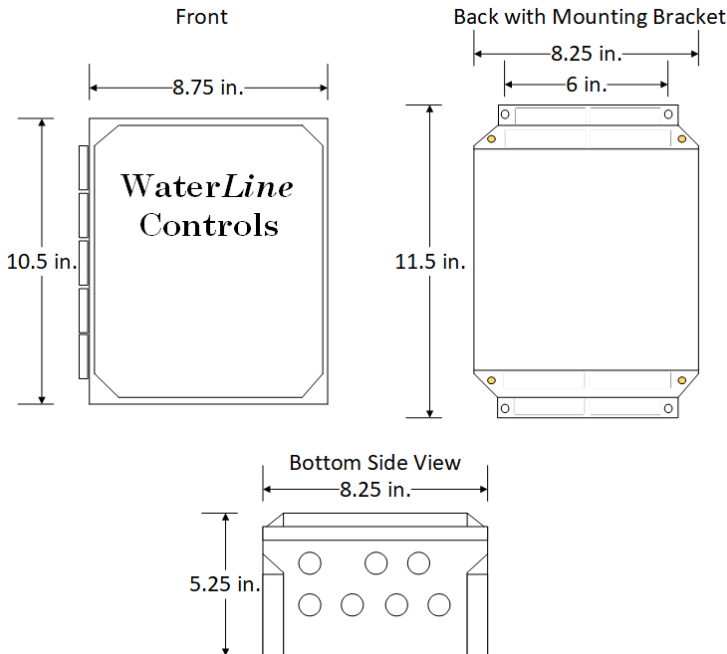

EXAMPLE FOR CONNECTING A 110VAC SOLENOID VALVE

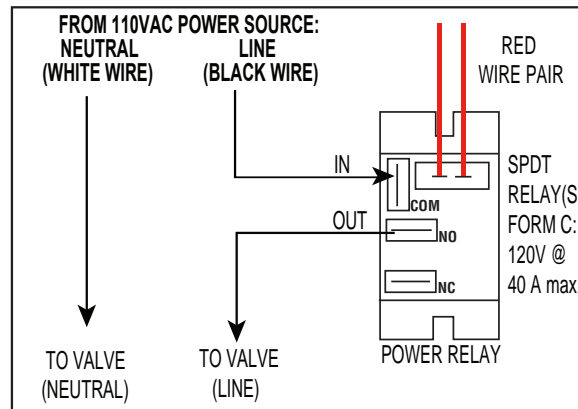

HIGH VOLTAGE POWER RELAYS

Form C - SPDT
 Rated max.: 120 VAC @ 40A
 All relays are typical
 All relay terminals are 1/4" male spade

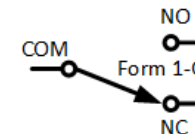

Phone: 480-905-1892
 www.waterlinecontrols.com
 Email: info@waterlinecontrols.com



WLC-6450D-110VAC SUBMITTAL

Duplex Fill (Alternating On, All Off) w/ Low & High Alarms

FUNCTIONAL DIAGRAMS

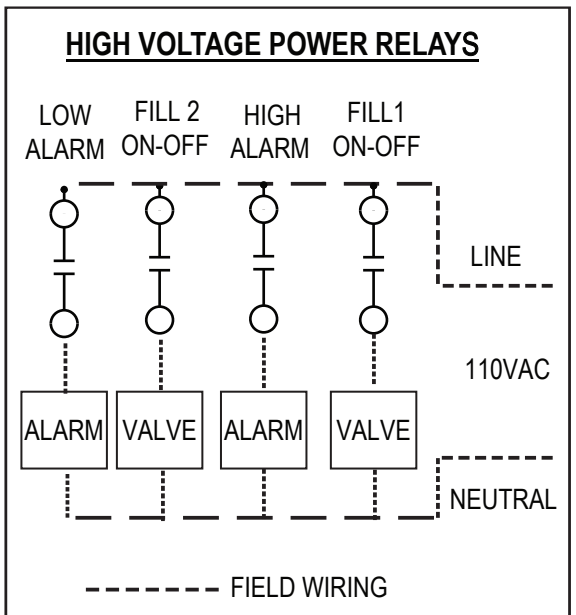
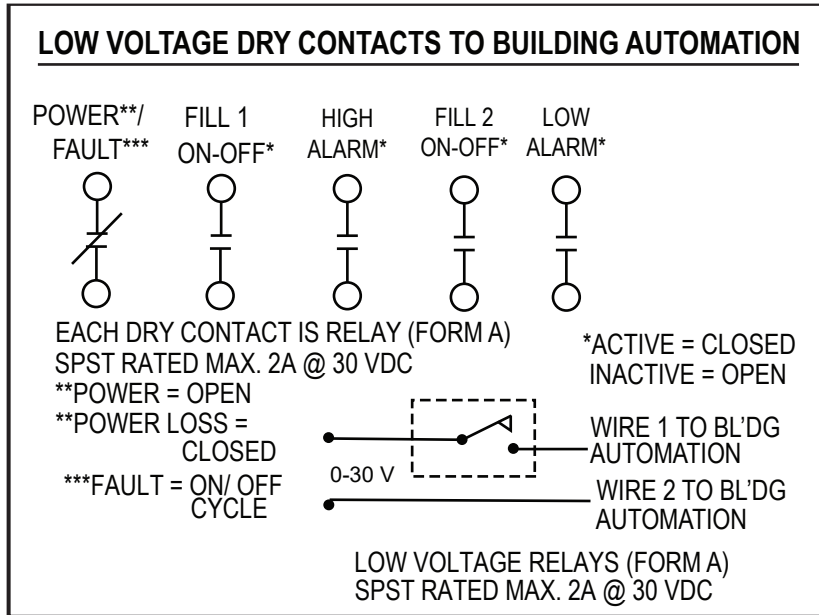
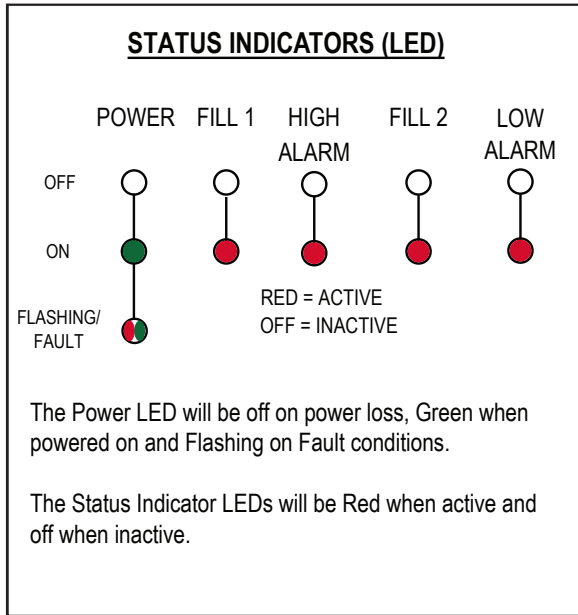

Example of 110VAC devices wired to power relays

PRODUCT FUNCTION TRUTH TABLE The Blank spaces below mean "No Connection or Function"

MODEL	BMS DRY CONTACTS						POWER RELAY				SELF TEST
	FAULT/ POWER LOSS	LOW ALARM	FILL 2	HIGH ALARM	FILL 1	BAS WIRES	LOW ALARM	FILL 2	HIGH ALARM	FILL 1	
WLC-6450D	X	X	X	X	X	10	X	X	X	X	X

Phone: 480-905-1892
 www.waterlinecontrols.com
 Email: info@waterlinecontrols.com

3060 Sensor

Standard Cable length is 50 ft.
 Available in 50ft increments up to 350 ft.
 Over 350 ft. please call
 All rods are 304 stainless steel with 1/4-20 threaded ends.
 Sensor rods can be extended using an Extension Rod kit accessory.
 Sensor rods & wires are Intrinsically safe with circuit limited signals.

LENGTHS			
SENSOR		Standard	
Green	HIGH ALARM	A	10-3/8"
Red	ALL OFF	B	14"
White	FILL 1 ON	C	15"
Brown	FILL 2 ON	D	16-3/8"
Blue	LOW ALARM	E	17"
Black	Same length as longest rod		

Optional Extension rod kit to extend rods by 45.5"
 Extension rods are threaded at each end to allow for any depths.
 PART # SENSOR-EXT6-45.5in

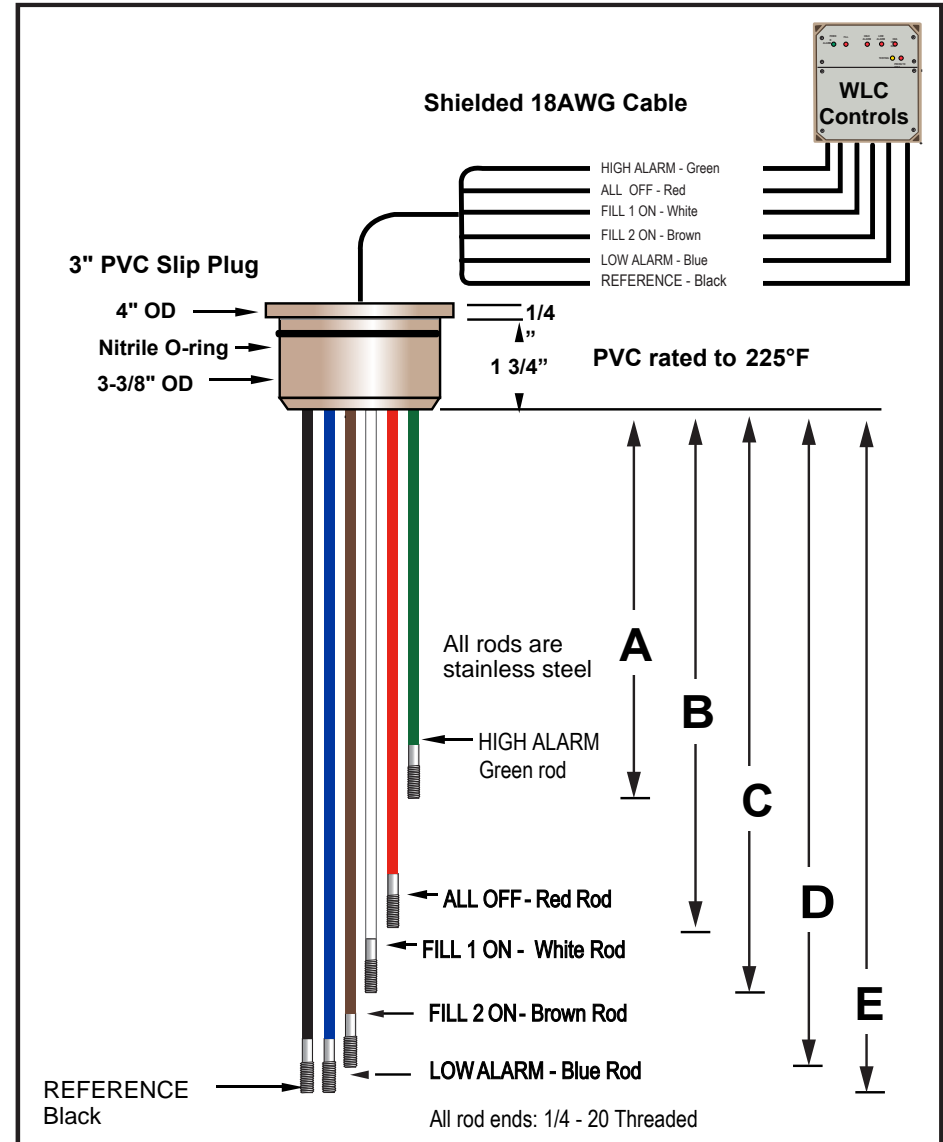

Phone: 480-905-1892
www.waterlinecontrols.com
 Email: info@waterlinecontrols.com

Electronic Water Level Management Systems

5 Year Limited Warranty - *WaterLine* Controls®

The 5 Year Limited Warranty is extended to the original consumer purchaser of this *WaterLine* Controls manufactured by *WaterLine* Controls, Scottsdale, Arizona. *WaterLine* Controls warrants the unit, including the parts and components thereof, to be free of defects in material and workmanship under normal use and service conditions. This warranty does not cover plumbing or normal replacement items and parts, including gaskets and O-rings. *WaterLine* Controls does not cover improper installation of the unit or its parts. If you have any questions regarding the installation of your *WaterLine* Controls unit, please feel free to contact us. Be sure to include the serial number of your unit.

The 5 Year Limited Warranty commences on the date of installation. Parts discovered to have manufacturing defects within 1 Year of installation shall be replaced at no charge to the original consumer. Defects discovered after one year and up to the fifth year following the installation, shall be replaced at a fee of \$275.00 per item. *WaterLine* Controls will repair or replace, at its option, a unit or part proved to be defective within the warranty period and under the conditions of this 5 Year Limited Warranty.

This 5 Year Limited Warranty does not apply if the failure is caused or contributed by any of the following: power surges, acts of God, power failure or reduction of power supplied to the unit, unusual atmospheric conditions, improper handling, improper storage, winter freezing, abuse, improper installation, unsuitable application, lack of reasonable and necessary maintenance, natural disasters, or repairs/alterations made or attempted by other than *WaterLine* Controls or an Authorized Technician approved by *WaterLine* Controls.

The consumer must deliver or ship the unit or warranty parts freight prepaid to *WaterLine* Controls. Authorization to return an item to *WaterLine* Controls must be obtained from *WaterLine* Controls Customer Service Department at 480-905-1892. For further assistance with this process please contact the Customer Service Department. Be sure you insure your shipment against loss or damage in transit.

WaterLine Controls is not responsible for the cost of removal of the unit or parts of the unit, damages due to removal, or any other expenses incurred, including in shipping the unit or parts to or from *WaterLine* Controls or its closest Authorized Service Center or the installation of the repaired or replaced unit. The consumer must bear these expenses.

THIS 5 YEAR LIMITED WARRANTY IS IN LIEU OF ALL OTHER WARRANTIES, EXPRESSED OR IMPLIED, INCLUDING THE IMPLIED WARRANTIES OF MERCHANTABILITY AND FITNESS FOR A PARTICULAR PURPOSE AND ALL SUCH OTHER WARRANTIES ARE DISCLAIMED EXCEPT TO THE EXTENT ANY IMPLIED WARRANTY MAY BE IMPOSED BY STATE CONSUMER LAW. ANY SUCH IMPLIED WARRANTY IMPOSED BY STATE CONSUMER LAW IS LIMITED IN DURATION TO ONE (1) YEAR FROM THE DATE OF INSTALLATION. IN NO EVENT SHALL *WATERLINE* CONTROLS BE LIABLE FOR INCIDENTAL OR CONSEQUENTIAL DAMAGES OR ANY NATURE OR KIND OR FOR DAMAGES TO PERSONS OR PROPERTY, INCLUDING ANY DAMAGE RESULTING FROM THE USE OF THE UNIT WITH A SUBSTANDARD WATER CIRCULATION OR SUPPLY SYSTEM.

Some states do not allow limitations on how long an implied warranty lasts, or the exclusion or limitation of incidental or consequential damages, so the above limitations may not apply to you.

This limited warranty is valid only in the United States of America and Canada.

WaterLine Controls • PO Box 12544 Scottsdale • Arizona 85267

Phone: 480-905-1892 Email: info@waterlinecontrols.com

© SDI 2024