



**Toll Free: 888-905-1892**  
**www.waterlinecontrols.com**  
Email: [info@waterlinecontrols.com](mailto:info@waterlinecontrols.com)

**NEW MORE RELIABLE TECHNOLOGY by Waterline Controls® FOR SPECIFYING ENGINEERS WITH A TESTED & PROVEN TRACK RECORD in MRO APPLICATIONS for 10+ years.**

**Our controls can REPLACE ALL SENSOR & CONTROL TYPES in ALL water based applications.**

**We ARE NOT similar to float switches, capacitive, conductive, ultrasonic, or pressure transducers.  
We ARE more reliable, easy to operate, & last longer**

## **Benefits:**

- Permanently eliminate float switches
- Water quality does not matter
- Sensor will not plate, foul, or deteriorate
- Flexibility in design to meet any scenario
- High-voltage is not near water
- Little to no maintenance
- Never needs recalibration
- Stand-alone controls
- Connections for BMS, BAS, or fire panel
- Less than 1% failure rate in the field
- Limited lifetime warranty
- Fully Commercialized

## **Features:**

- Dry contacts for BMS, BAS, or fire panel
- Power relays for valves, pumps, etc.
- Intuitive LED indicators
- Optional temperature sensor controlled relay
- NEMA 4x control enclosure
- Controls can be mounted in equipment room w/ sensor wired remotely
- Intrinsically safe
- Color coded sensor rods & wires for intuitive installation
- Fully automated by microprocessor
- Push-button for relay test
- Only moving parts are replaceable relays
- Modular construction

Waterline Controls  
P.O. Box 12544 Scottsdale, Arizona 85260  
Toll Free: 888-905-1892  
Email: [info@waterlinecontrols.com](mailto:info@waterlinecontrols.com)  
[www.waterlinecontrols.com](http://www.waterlinecontrols.com)



# SUBMITTAL WLC-6000E-HA FUNCTIONAL WIRING DIAGRAM OUTPUTS

## 4 Level Low Water Alarm w/ High Alarm, Beacon & Audible Alarm

### LED STATUS INDICATORS

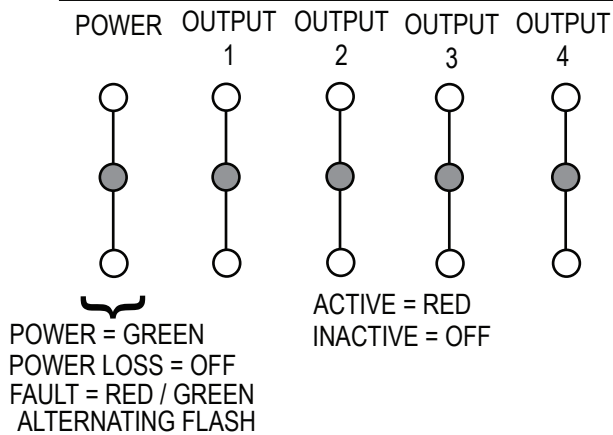

### LOW VOLTAGE DRY CONTACTS TO BUILDING AUTOMATION

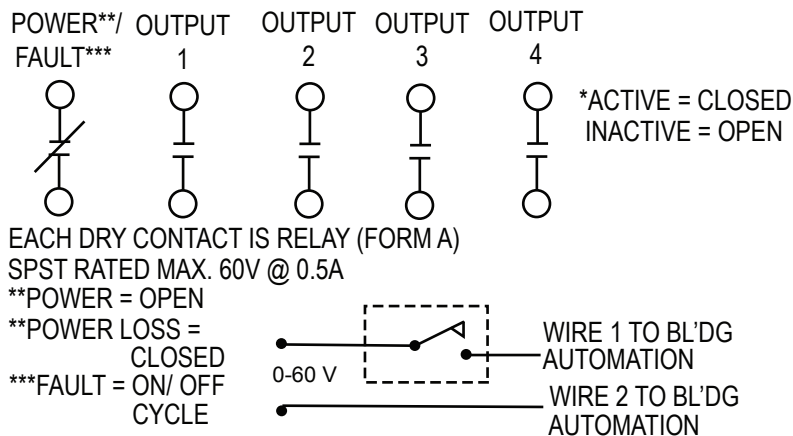

LOW VOLTAGE RELAYS (FORM A) SPST  
RATED MAX. 60V @ 0.5A

### HIGH VOLTAGE POWER RELAY DRY CONTACTS

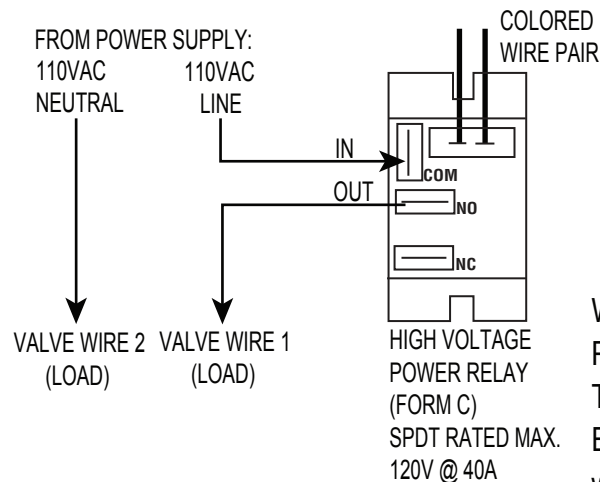
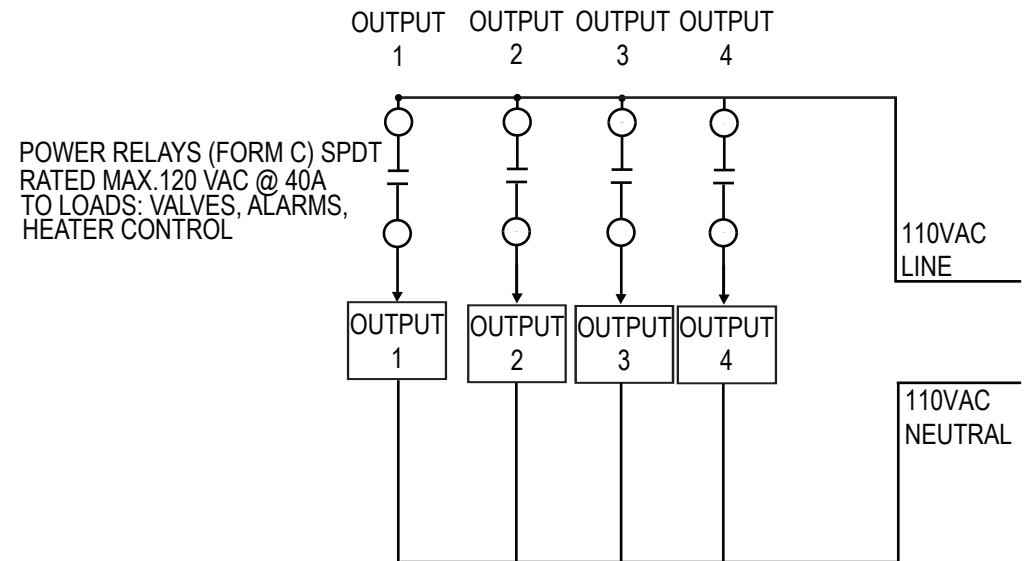

Waterline Controls  
P.O. Box 12544 Scottsdale, Arizona 85260  
Toll Free: 888-905-1892  
Email: [info@waterlinecontrols.com](mailto:info@waterlinecontrols.com)  
[www.waterlinecontrols.com](http://www.waterlinecontrols.com)



# SUBMITTAL WLC-6000E-HA

## 4 Level Low Water Alarm w/ High Alarm, Beacon & Audible Alarm

**LOW VOLTAGE DRY CONTACTS TO BUILDING AUTOMATION**  
RATED MAX. 60V @ 0.5A

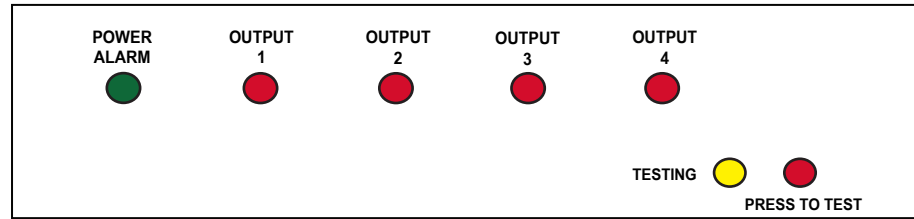
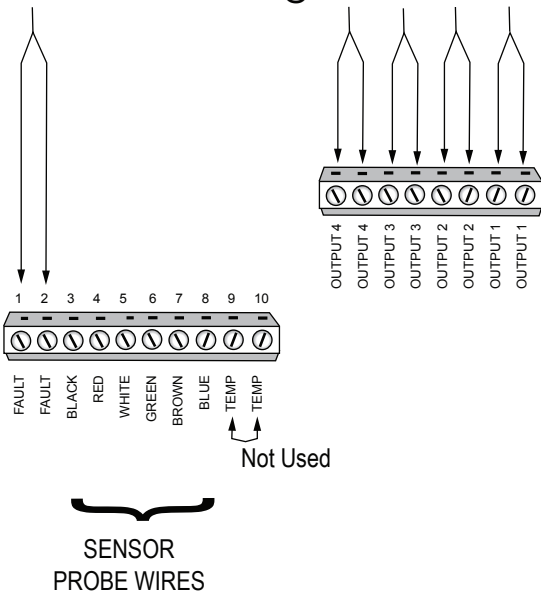

**CONTROL UNIT RATINGS**  
VOLTS: 110 VAC (50/60 HZ)  
AMPS: 0.5 AMPS  
WATTS: 55W

### HIGH VOLTAGE POWER RELAYS

Form C - SPDT  
Rated max.: 120 VAC @ 40A  
All relays are typical  
All relay terminals are 1/4" male spade

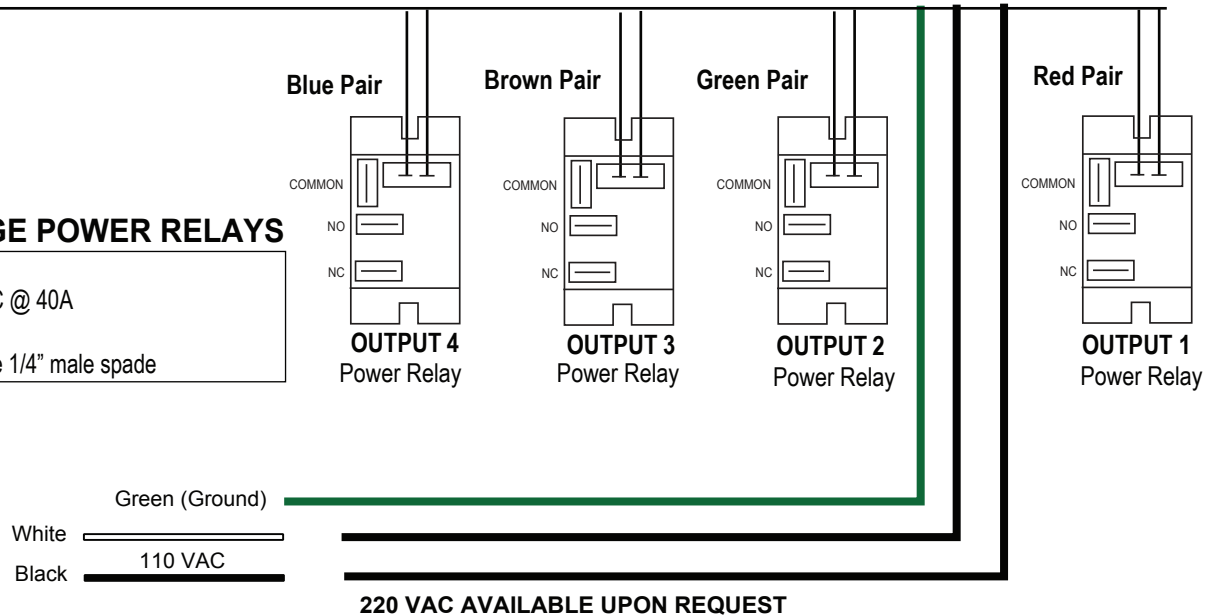

### PRODUCT FUNCTION TRUTH TABLE

MODEL	BMS DRY CONTACTS							POWER RELAY				SELF TEST
	FAULT	POWER LOSS	OUTPUT 4	OUTPUT 3	OUTPUT 2	OUTPUT 1	BAS WIRES	OUTPUT 4	OUTPUT 3	OUTPUT 2	OUTPUT 1	
WLC-6000E-HA	X	X	X	X	X	X	10	X	X	X	X	X

Waterline Controls  
P.O. Box 12544 Scottsdale, Arizona 85260  
Toll Free: 888-905-1892  
Email: [info@waterlinecontrols.com](mailto:info@waterlinecontrols.com)  
[www.waterlinecontrols.com](http://www.waterlinecontrols.com)



# SUBMITTAL WLC-6000E-HA 4 Level Low Water Alarm w/ High Alarm, Beacon & Audible Alarm

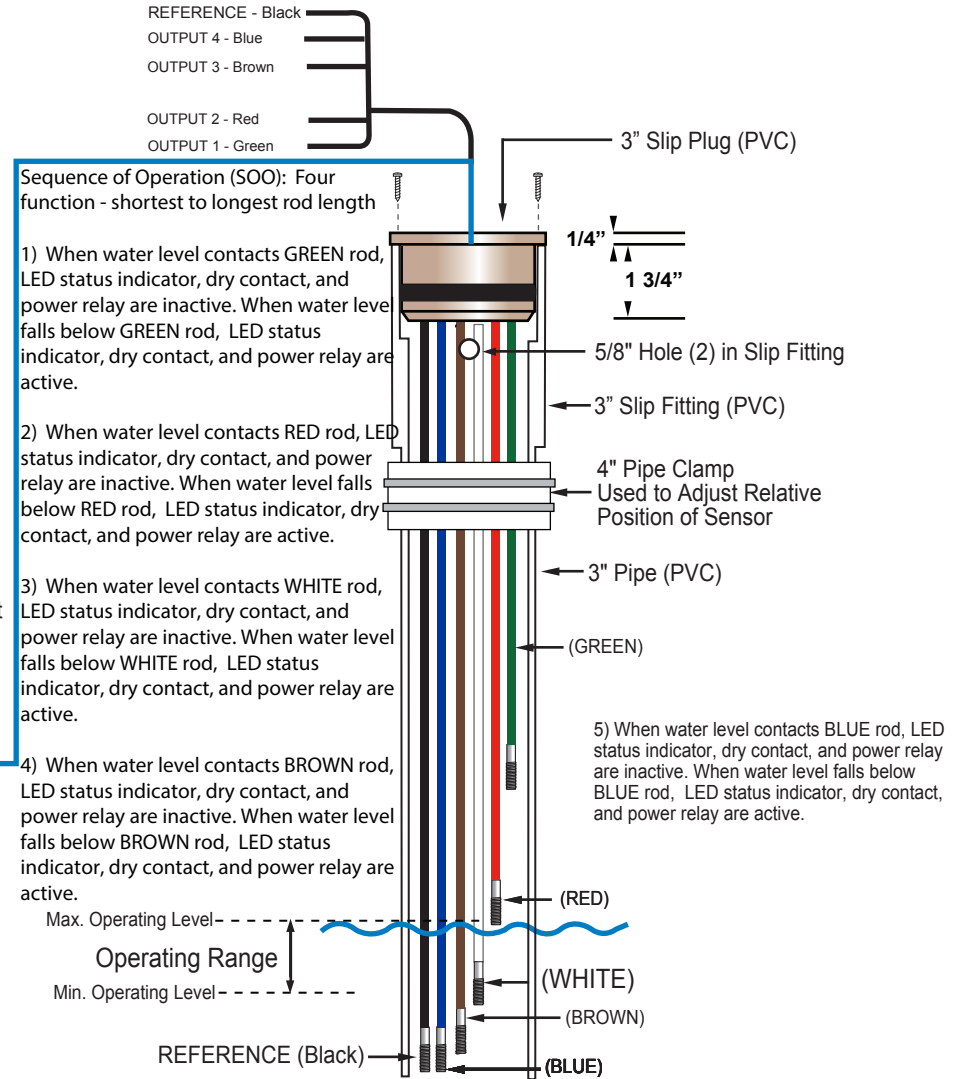
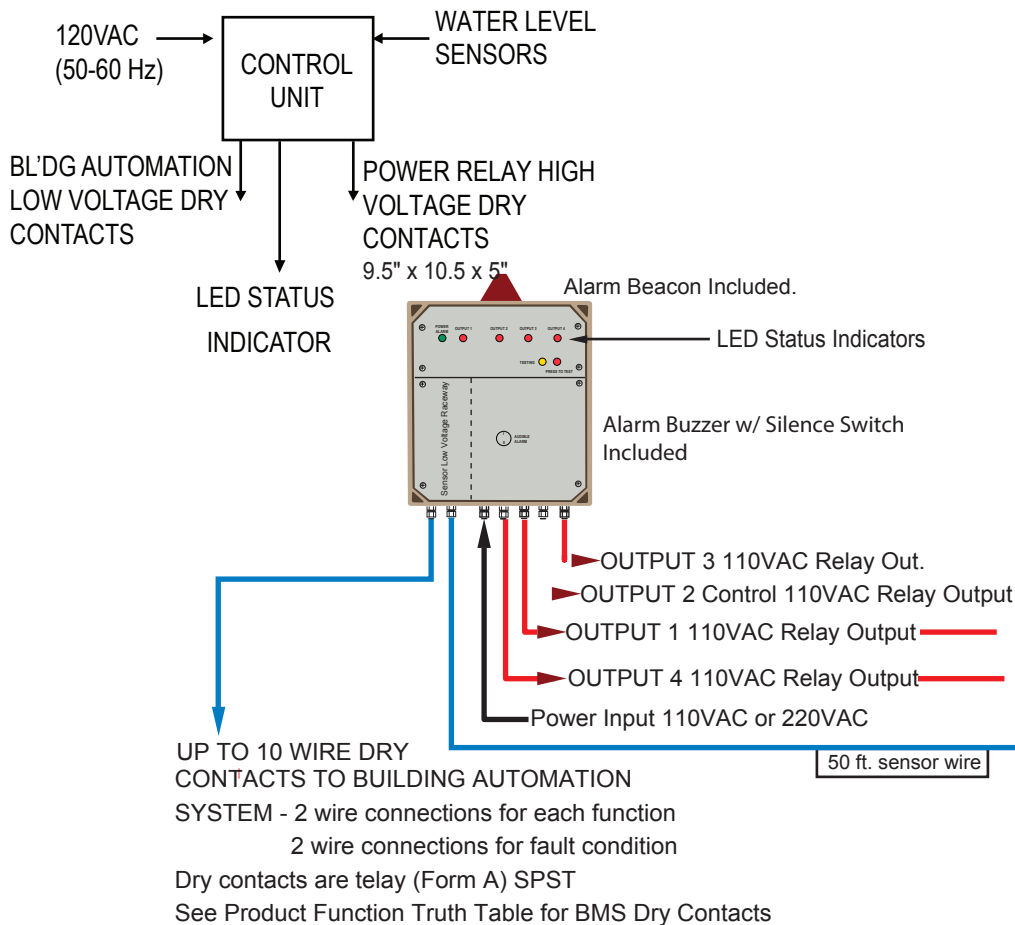

1. 3" PVC pipe of length greater than or equal to length of longest rod
2. Adjust by moving 3" PVC Pipe upward/ downward, then tighten clamp

Waterline Controls  
P.O. Box 12544 Scottsdale, Arizona 85260  
Toll Free: 888-905-1892  
Email: [info@waterlinecontrols.com](mailto:info@waterlinecontrols.com) • [www.waterlinecontrols.com](http://www.waterlinecontrols.com)

# Electronic Water Level Management Systems

## 5 Year Limited Warranty - *WaterLine* Controls®

The 5 Year Limited Warranty is extended to the original consumer purchaser of this *WaterLine* Controls manufactured by *WaterLine* Controls, Scottsdale, Arizona. *WaterLine* Controls warrants the unit, including the parts and components thereof, to be free of defects in material and workmanship under normal use and service conditions. This warranty does not cover plumbing or normal replacement items and parts, including gaskets and O-rings. *WaterLine* Controls does not cover improper installation of the unit or its parts. If you have any questions regarding the installation of your *WaterLine* Controls unit, please feel free to contact us. Be sure to include the serial number of your unit.

The 5 Year Limited Warranty commences on the date of installation. Parts discovered to have manufacturing defects within 1 Year of installation shall be replaced at no charge to the original consumer. Defects discovered after one year and up to the fifth year following the installation, shall be replaced at a fee of \$275.00 per item. *WaterLine* Controls will repair or replace, at its option, a unit or part proved to be defective within the warranty period and under the conditions of this 5 Year Limited Warranty.

This 5 Year Limited Warranty does not apply if the failure is caused or contributed by any of the following: power failure or reduction of power supplied to the unit, unusual atmospheric conditions, improper handling, improper storage, winter freezing, abuse, improper installation, unsuitable application, lack of reasonable and necessary maintenance, natural disasters, or repairs/alterations made or attempted by other than *WaterLine* Controls or an Authorized Technician approved by *WaterLine* Controls.

The consumer must deliver or ship the unit or warranty parts freight prepaid to *WaterLine* Controls. Authorization to return an item to *WaterLine* Controls must be obtained from *WaterLine* Controls Customer Service Department at 888-905-1892. For further assistance with this process please contact the Customer Service Department. Be sure you insure your shipment against loss or damage in transit.

*WaterLine* Controls is not responsible for the cost of removal of the unit or parts of the unit, damages due to removal, or any other expenses incurred in shipping the unit or parts to or from *WaterLine* Controls or its closest Authorized Service Center or the installation of the repaired or replaced unit. The consumer must bear these expenses.

THIS 5 YEAR LIMITED WARRANTY IS IN LIEU OF ALL OTHER WARRANTIES, EXPRESSED OR IMPLIED, INCLUDING THE IMPLIED WARRANTIES OF MERCHANTABILITY AND FITNESS FOR A PARTICULAR PURPOSE AND ALL SUCH OTHER WARRANTIES ARE DISCLAIMED EXCEPT TO THE EXTENT ANY IMPLIED WARRANTY MAY BE IMPOSED BY STATE CONSUMER LAW. ANY SUCH IMPLIED WARRANTY IMPOSED BY STATE CONSUMER LAW IS LIMITED IN DURATION TO ONE (1) YEAR FROM THE DATE OF INSTALLATION. IN NO EVENT SHALL *WATERLINE* CONTROLS BE LIABLE FOR INCIDENTAL OR CONSEQUENTIAL DAMAGES OR ANY NATURE OR KIND OR FOR DAMAGES TO PERSONS OR PROPERTY, INCLUDING ANY DAMAGE RESULTING FROM THE USE OF THE UNIT WITH A SUBSTANDARD WATER CIRCULATION OR SUPPLY SYSTEM.

Some states do not allow limitations on how long an implied warranty lasts, or the exclusion or limitation of incidental or consequential damages, so the above limitations may not apply to you.

This limited warranty is valid only in the United States of America and Canada.

*WaterLine* Controls • PO Box 12544 Scottsdale • Arizona 85260

Phone: 888-905-1892      Email: [info@waterlinecontrols.com](mailto:info@waterlinecontrols.com)

© SDI 2019