



Toll Free: 888-905-1892
www.waterlinecontrols.com
Email: info@waterlinecontrols.com

NEW MORE RELIABLE TECHNOLOGY by Waterline Controls® FOR SPECIFYING ENGINEERS WITH A TESTED & PROVEN TRACK RECORD in MRO APPLICATIONS for 10+ years.

Our controls can REPLACE ALL SENSOR & CONTROL TYPES in ALL water based applications.

**We ARE NOT similar to float switches, capacitive, conductive, ultrasonic, or pressure transducers.
We ARE more reliable, easy to operate, & last longer**

Benefits:

- Permanently eliminate float switches
- Water quality does not matter
- Sensor will not plate, foul, or deteriorate
- Flexibility in design to meet any scenario
- High-voltage is not near water
- Little to no maintenance
- Never needs recalibration
- Stand-alone controls
- Connections for BMS, BAS, or fire panel
- Less than 1% failure rate in the field
- Limited lifetime warranty
- Fully Commercialized

Features:

- Dry contacts for BMS, BAS, or fire panel
- Power relays for valves, pumps, etc.
- Intuitive LED indicators
- Optional temperature sensor controlled relay
- NEMA 4x control enclosure
- Controls can be mounted in equipment room w/ sensor wired remotely
- Intrinsically safe
- Color coded sensor rods & wires for intuitive installation
- Fully automated by microprocessor
- Push-button for relay test
- Only moving parts are replaceable relays
- Modular construction

Waterline Controls
P.O. Box 12544 Scottsdale, Arizona 85260
Toll Free: 888-905-1892
Email: info@waterlinecontrols.com
www.waterlinecontrols.com



SUBMITTAL FPT 42

FIRE PROTECTION WATER LEVEL ALARMS

FUNCTIONAL WIRING DIAGRAM OUTPUTS

Water Level Low-low, Low, & High Alarms

LED STATUS INDICATORS

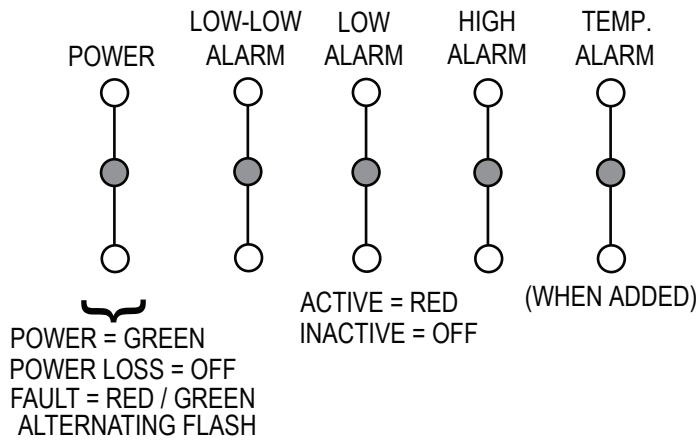

LOW VOLTAGE DRY CONTACTS TO FIRE PANEL

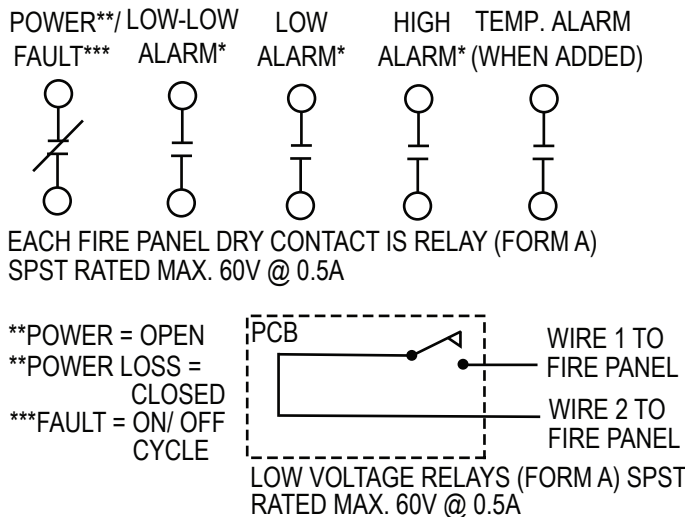

HIGH VOLTAGE POWER RELAY DRY CONTACTS

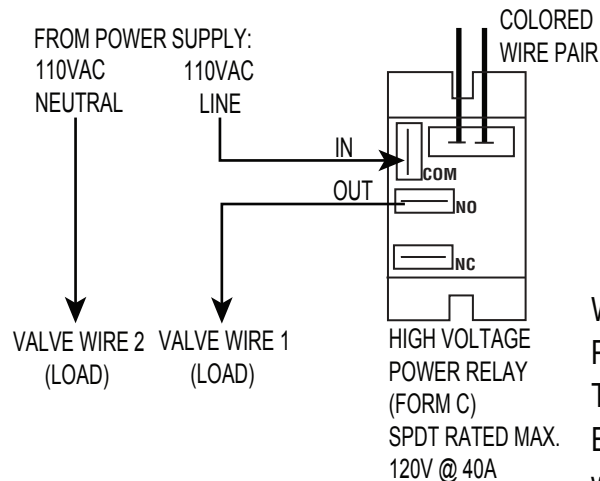
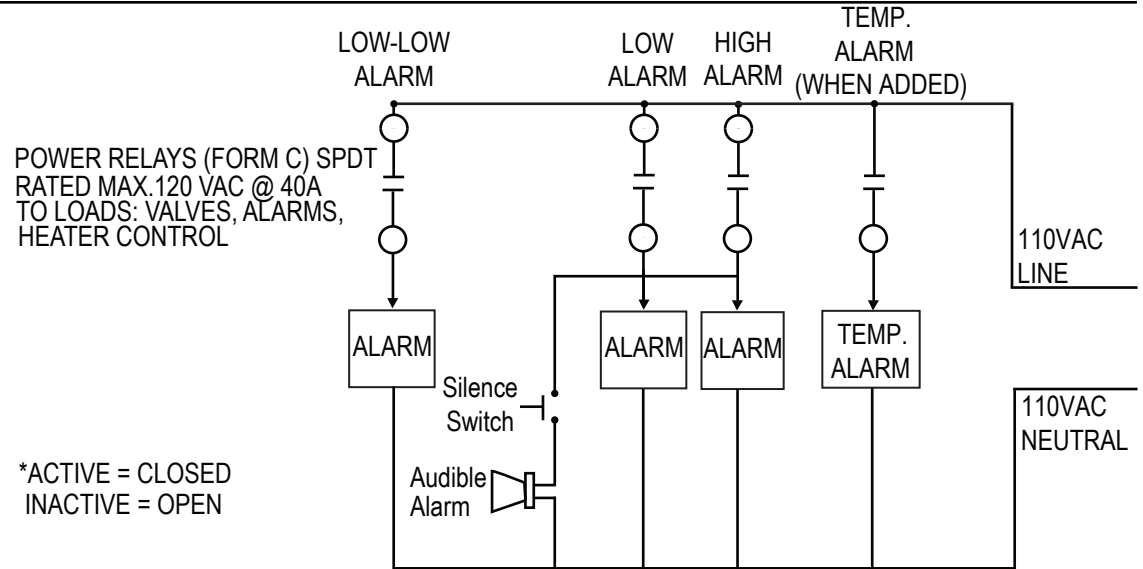

Waterline Controls
P.O. Box 12544 Scottsdale, Arizona 85260
Toll Free: 888-905-1892
Email: info@waterlinecontrols.com
www.waterlinecontrols.com

Water Level Low-low, Low, & High Alarms

LOW VOLTAGE DRY CONTACTS TO FIRE PANEL
RATED MAX. 60V @ 0.5A

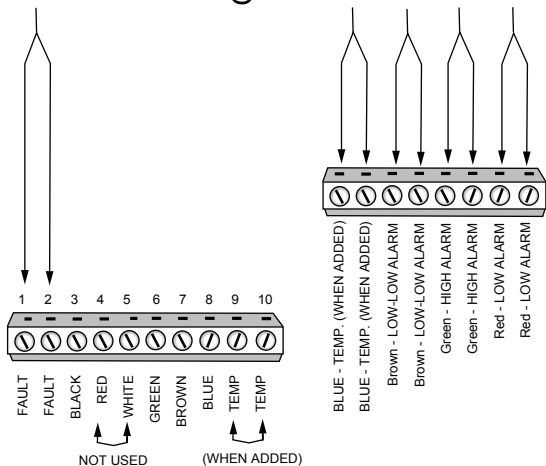

SENSOR PROBE WIRES

HIGH VOLTAGE POWER RELAYS

Form C - SPDT
 Rated max.: 120 VAC @ 40A
 All relays are typical
 All relay terminals are 1/4" male spade

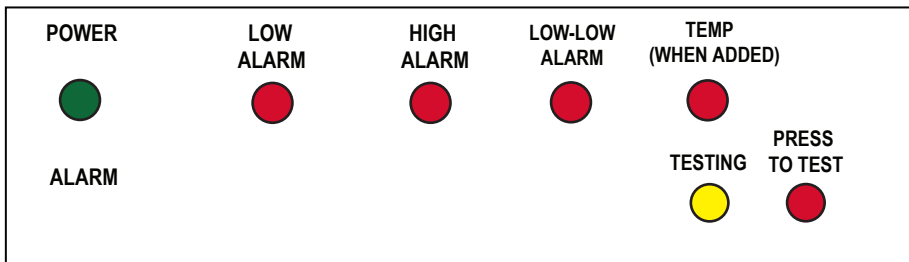

CONTROL UNIT RATINGS
 VOLTS: 110 VAC (50/60 HZ)
 AMPS: 0.5 AMPS
 WATTS: 55W

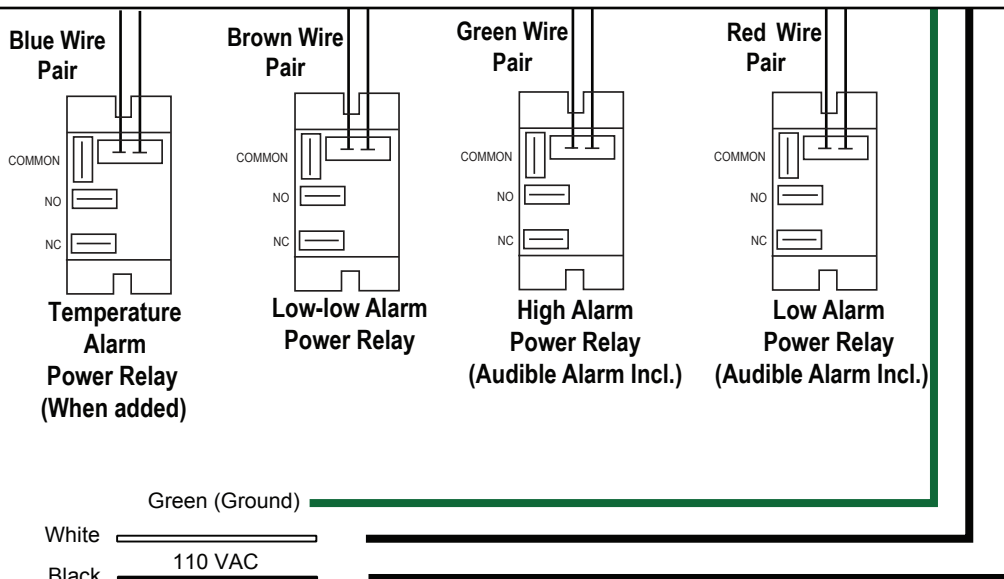

220 VAC AVAILABLE UPON REQUEST

PRODUCT FUNCTION TRUTH TABLE The Blank spaces below mean "No Connection or Function"

MODEL	BMS DRY CONTACTS							POWER RELAY				SELF TEST
	FAULT	POWER LOSS	LOW-LOW ALARM	LOW ALARM	HIGH ALARM	TEMPERATURE	BAS WIRES	LOW-LOW ALARM	LOW ALARM	HIGH ALARM	TEMPERATURE	
FPT 42	X	X	X	X	X	(Opt.)	8-10	X	X	X	(Opt.)	X

Waterline Controls
 P.O. Box 12544 Scottsdale, Arizona 85260
 Toll Free: 888-905-1892
 Email: info@waterlinecontrols.com
www.waterlinecontrols.com



SUBMITTAL WLC FPT 42

FIRE PROTECTION WATER LEVEL ALARMS

Water Level Low-low, Low, & High Alarms

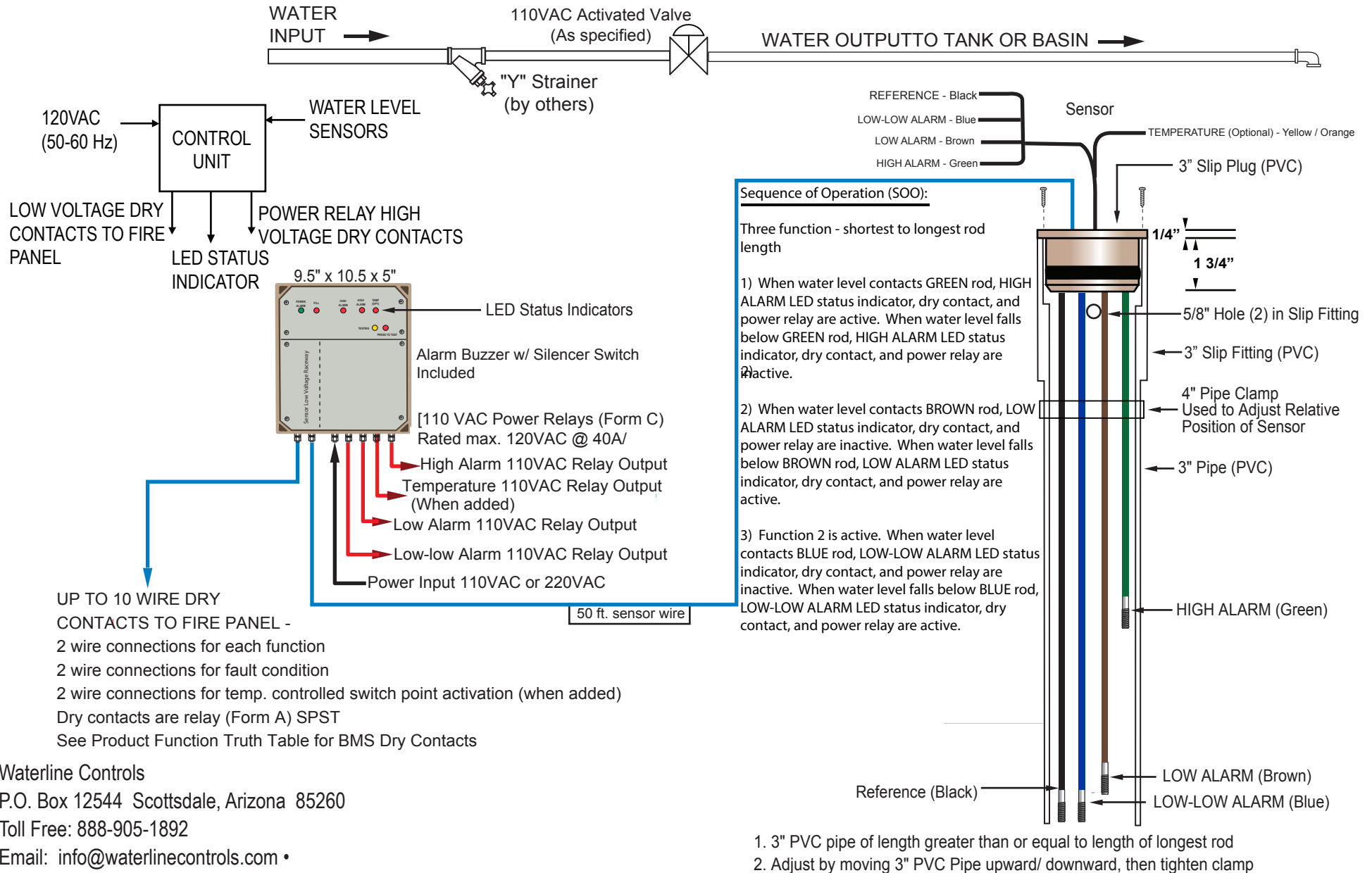

Waterline Controls
 P.O. Box 12544 Scottsdale, Arizona 85260
 Toll Free: 888-905-1892
 Email: info@waterlinecontrols.com
www.waterlinecontrols.com



SUBMITTAL WLC FPT 42

FIRE PROTECTION WATER LEVEL ALARMS

OPTIONAL TEMPERATURE SENSOR

Temperature Sensor Options

Temperature Sensor Option 1:
Integrated in Sensor Head (Part # SENSOR 3040BBGT)

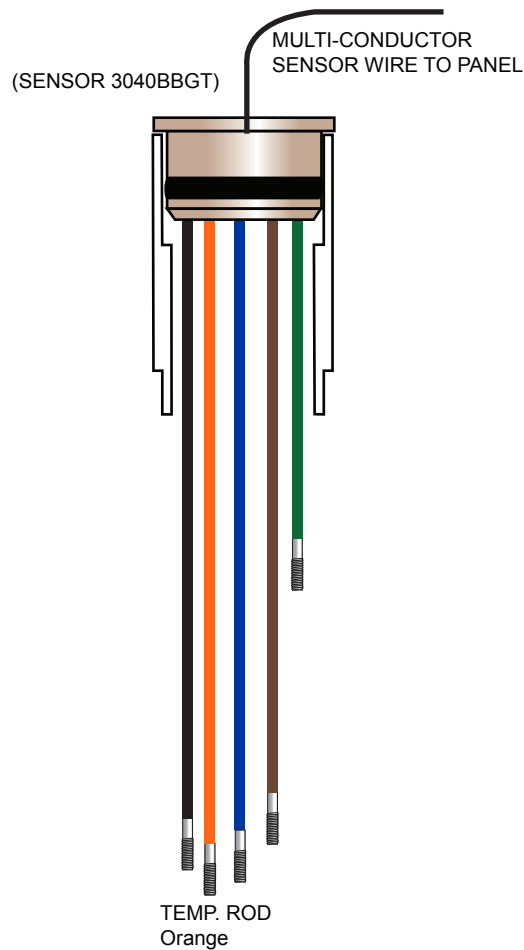

Temperature Sensor Option 2:
Side of Tank Mount (Part #SENSOR TTSM)

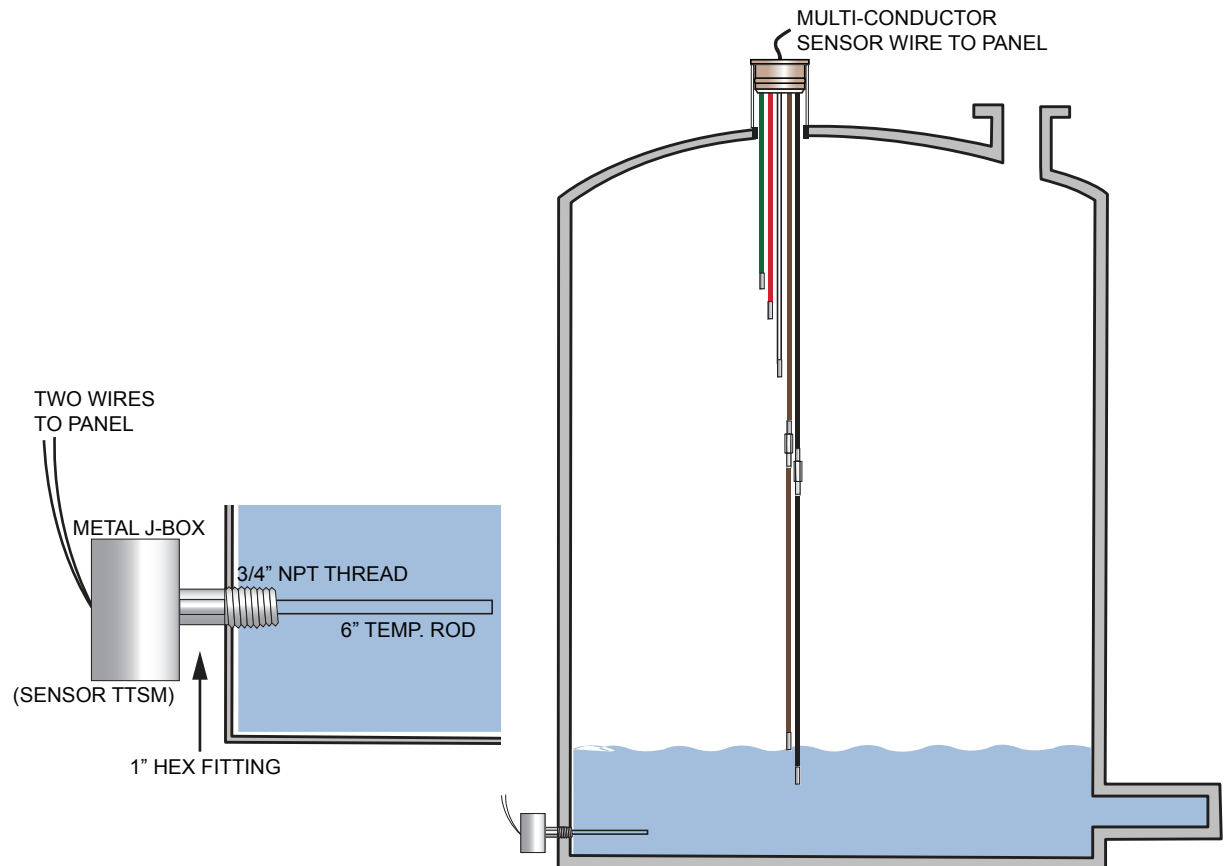

Waterline Controls
P.O. Box 12544 Scottsdale, Arizona 85260
Toll Free: 888-905-1892
Email: info@waterlinecontrols.com
www.waterlinecontrols.com

Electronic Water Level Management Systems

5 Year Limited Warranty - *WaterLine* Controls®

The 5 Year Limited Warranty is extended to the original consumer purchaser of this *WaterLine* Controls manufactured by *WaterLine* Controls, Scottsdale, Arizona. *WaterLine* Controls warrants the unit, including all the parts and components thereof, to be free of defects in material and workmanship. This warranty does not cover plumbing or normal replacement items and parts, including gaskets and O-rings. *WaterLine* Controls does not cover improper installation of the unit or its parts, but our instruction manual is complete enough to solve any issues - particularly if the manual is read before rather than after the installation. If you have any questions including installation questions regarding your *WaterLine* Controls unit, please feel free to contact us. Be sure to include the serial number of your unit.

The 5 Year Limited Warranty commences on the date of installation. All parts discovered to have manufacturing defects within 12 months of installation shall be replaced at no charge to the customer. Any defect discovered after 12 months following the installation, shall have a fee of \$275.00 for replacement of the items discovered to be defective up to and including the fifth year.

This 5 Year Limited Warranty does not apply if the failure is caused or contributed by any of the following: power failure or reduction of power supplied to the unit, unusual atmospheric conditions, improper handling, improper storage, winter freezing, abuse, improper installation, unsuitable application, lack of reasonable and necessary maintenance, natural disasters, or repairs/alterations made or attempted by other than *WaterLine* Controls or an Authorized Technician approved by *WaterLine* Controls. *WaterLine* Controls will repair or replace, at its option, a unit or part proved to be defective within the warranty period and under the conditions of this 5 Year Limited Warranty.

WaterLine Controls • PO Box 12544 Scottsdale • Arizona 85260

The consumer must deliver or ship the unit or warranty parts freight prepaid to *WaterLine* Controls. Authorization to return an item to *WaterLine* Controls must be obtained from *WaterLine* Controls Customer Service Department at 888-905-1892. For further assistance with this process please contact the Customer Service Department. Be sure you insure your shipment against loss or damage in transit.

WaterLine Controls is not responsible for the cost of removal of the unit or parts of the unit, damages due to removal, or any other expenses incurred in shipping the unit or parts to or from *WaterLine* Controls or its closest Authorized Service Center or the installation of the repaired or replaced unit. The consumer must bear these expenses.

THIS 5 YEAR LIMITED WARRANTY IS IN LIEU OF ALL OTHER WARRANTIES, EXPRESSED OR IMPLIED, INCLUDING THE IMPLIED WARRANTIES OF MERCHANTABILITY AND FITNESS FOR A PARTICULAR PURPOSE AND ALL SUCH OTHER WARRANTIES ARE DISCLAIMED EXCEPT TO THE EXTENT ANY IMPLIED WARRANTY MAY BE IMPOSED BY STATE CONSUMER LAW. ANY SUCH IMPLIED WARRANTY IMPOSED BY STATE CONSUMER LAW IS LIMITED IN DURATION TO ONE (1) YEAR FROM THE DATE OF INSTALLATION. IN NO EVENT SHALL *WATERLINE* CONTROLS BE LIABLE FOR INCIDENTAL OR CONSEQUENTIAL DAMAGES OR ANY NATURE OR KIND OR FOR DAMAGES TO PERSONS OR PROPERTY, INCLUDING ANY DAMAGE RESULTING FROM THE USE OF THE UNIT WITH A SUBSTANDARD WATER CIRCULATION OR SUPPLY SYSTEM.

Some states do not allow limitations on how long an implied warranty lasts, or the exclusion or limitation of incidental or consequential damages, so the above limitations may not apply to you.

This limited warranty is valid only in the United States of America and Canada