



Toll Free: 888-905-1892
www.waterlinecontrols.com
Email: info@waterlinecontrols.com

**NEW MORE RELIABLE TECHNOLOGY by Waterline Controls® FOR SPECIFYING ENGINEERS
WITH A TESTED & PROVEN TRACK RECORD in MRO APPLICATIONS for 10+ years.**

Our controls can REPLACE ALL SENSOR & CONTROL TYPES in ALL water based applications.

**We ARE NOT similar to float switches, capacitive, conductive, ultrasonic, or pressure transducers.
We ARE more reliable, easy to operate, & last longer**

Benefits:

- Permanently eliminate float switches
- Water quality does not matter
- Sensor will not plate, foul, or deteriorate
- Flexibility in design to meet any scenario
- High-voltage is not near water
- Little to no maintenance
- Never needs recalibration
- Stand-alone controls
- Connections for BMS, BAS, or fire panel
- Less than 1% failure rate in the field
- Limited lifetime warranty
- Fully Commercialized

Features:

- Dry contacts for BMS, BAS, or fire panel
- Power relays for valves, pumps, etc.
- Intuitive LED indicators
- Optional temperature sensor controlled relay
- NEMA 4x control enclosure
- Controls can be mounted in equipment room w/ sensor wired remotely
- Intrinsically safe
- Color coded sensor rods & wires for intuitive installation
- Fully automated by microprocessor
- Push-button for relay test
- Only moving parts are replaceable relays
- Modular construction

Waterline Controls
P.O. Box 12544 Scottsdale, Arizona 85260
Toll Free: 888-905-1892
Email: info@waterlinecontrols.com
www.waterlinecontrols.com

Water Heater Control and Water Temperature Alarm

LED STATUS INDICATORS

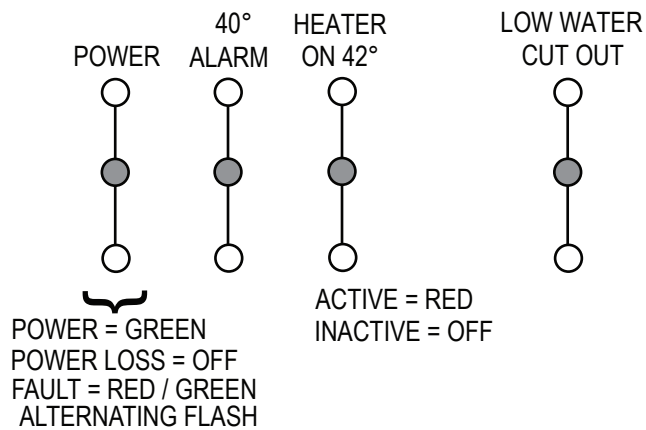

LOW VOLTAGE DRY CONTACTS TO BUILDING AUTOMATION

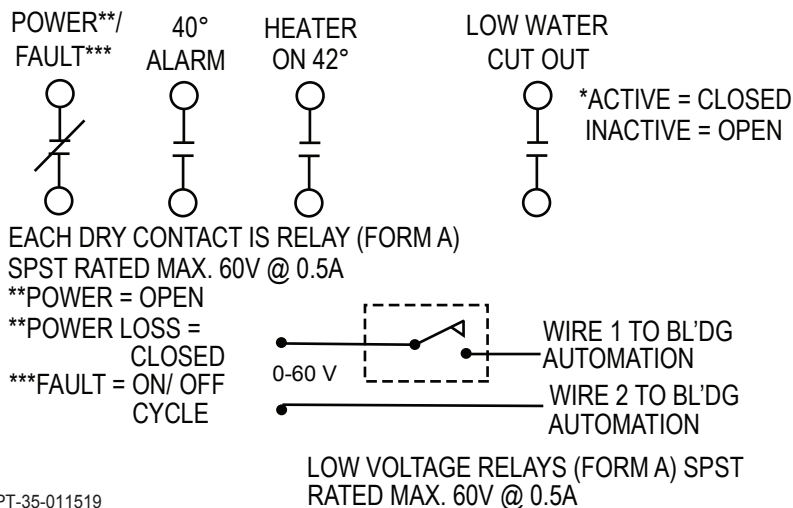

HIGH VOLTAGE POWER RELAY DRY CONTACTS

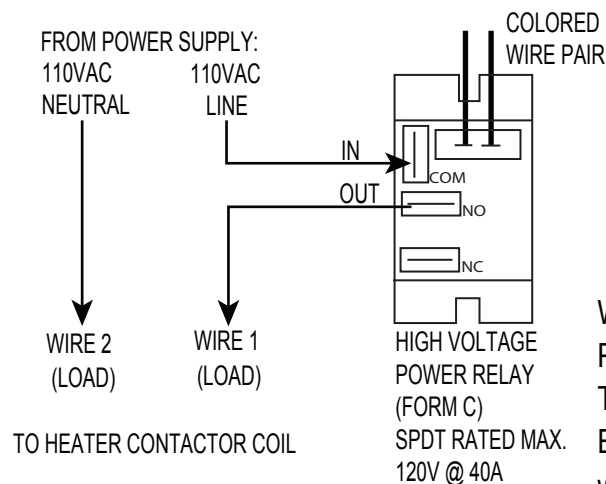
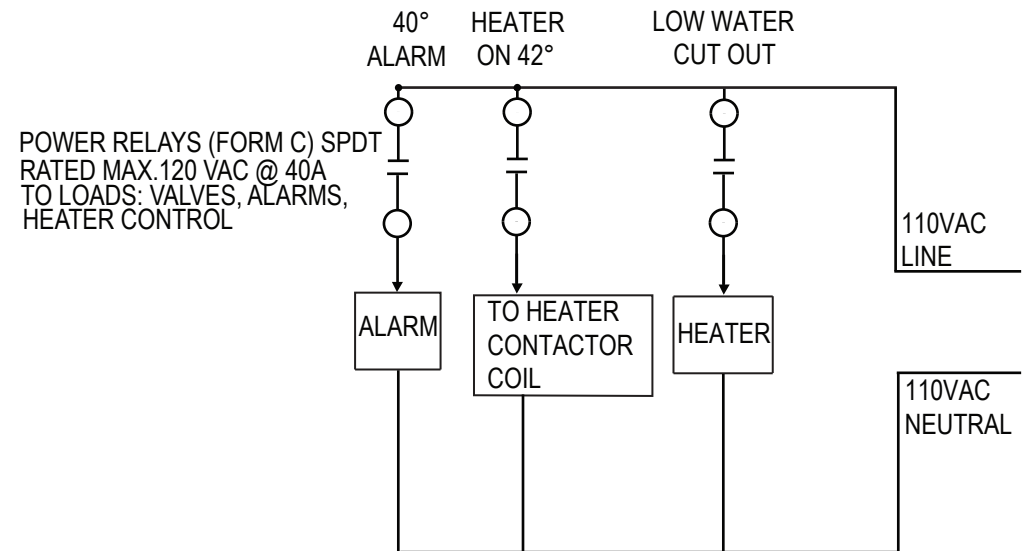

Waterline Controls
 P.O. Box 12544 Scottsdale, Arizona 85260
 Toll Free: 888-905-1892
 Email: info@waterlinecontrols.com
www.waterlinecontrols.com



SUBMITTAL FPT-35

Water Heater Control and Water Temperature Alarm

LOW VOLTAGE DRY CONTACTS TO BUILDING AUTOMATION
 RATED MAX. 60V @ 0.5A

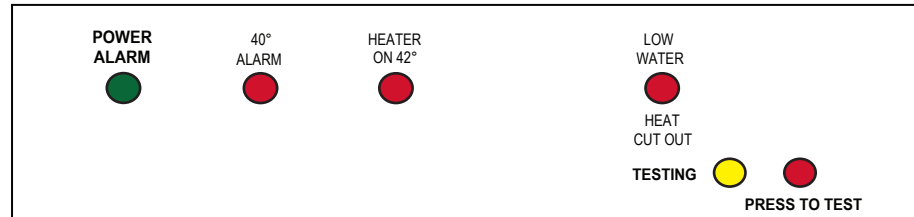
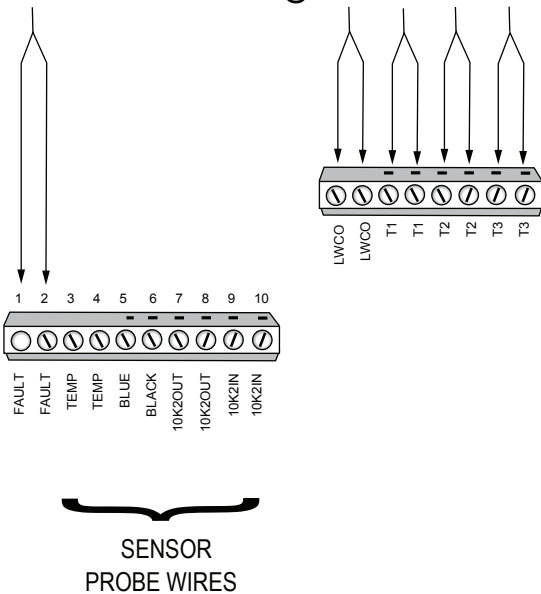

CONTROL UNIT RATINGS
VOLTS: 110 VAC (50/60 HZ)
AMPS: 0.5 AMPS
WATTS: 55W

HIGH VOLTAGE POWER RELAYS

Form C - SPDT
 Rated max.: 120 VAC @ 40A
 All relays are typical
 All relay terminals are 1/4" male spade

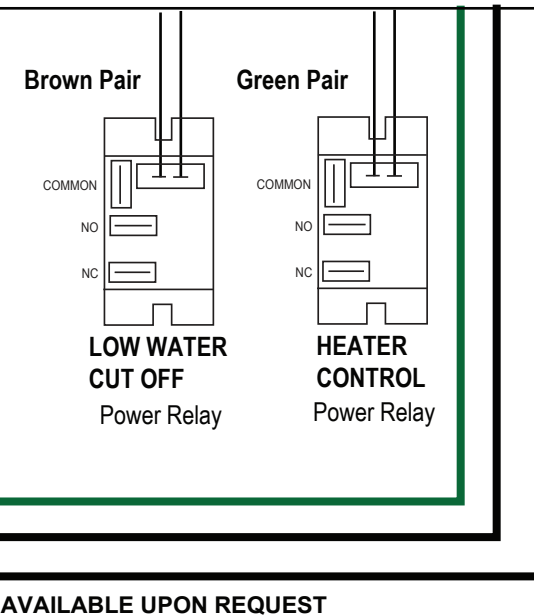

PRODUCT FUNCTION TRUTH TABLE

MODEL	BMS DRY CONTACTS							POWER RELAY				SELF TEST
	FAULT	POWER LOSS	HEATER CUT OUT	LOW ALARM	HIGH ALARM	FILL	BAS WIRES	HEATER	LOW ALARM	HIGH ALARM	FILL	
WLCTWLCO			X	X			10	X				

Waterline Controls
 P.O. Box 12544 Scottsdale, Arizona 85260
 Toll Free: 888-905-1892
 Email: info@waterlinecontrols.com
www.waterlinecontrols.com

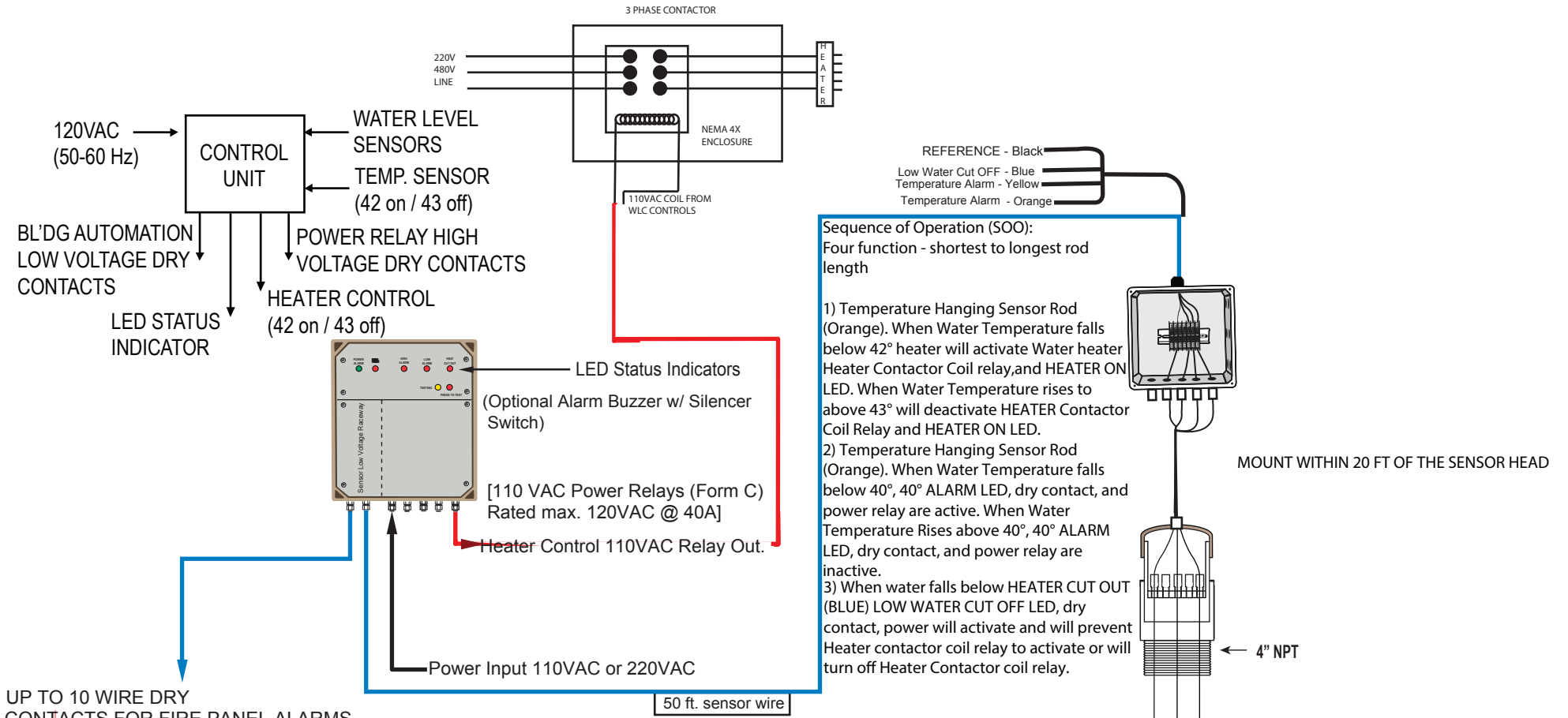

Sequence of Operation (SOO):
Four function - shortest to longest rod length

1) Temperature Hanging Sensor Rod (Orange). When Water Temperature falls below 42° heater will activate Water heater Heater Contactor Coil relay, and HEATER ON LED. When Water Temperature rises to above 43° will deactivate HEATER Contactor Coil Relay and HEATER ON LED.

2) Temperature Hanging Sensor Rod (Orange). When Water Temperature falls below 40°, 40° ALARM LED, dry contact, and power relay are active. When Water Temperature Rises above 40°, 40° ALARM LED, dry contact, and power relay are inactive.

3) When water falls below HEATER CUT OUT (BLUE) LOW WATER CUT OFF LED, dry contact, power will activate and will prevent Heater contactor coil relay to activate or will turn off Heater Contactor coil relay.

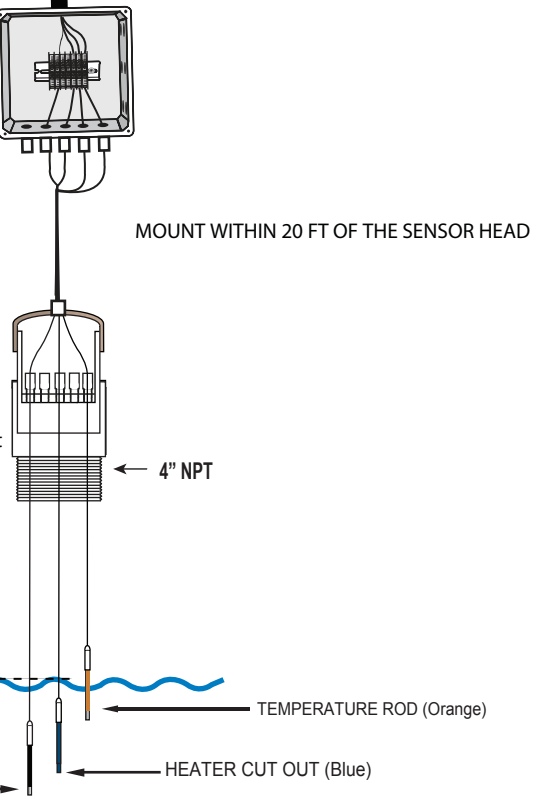

1. 3" PVC pipe of length greater than or equal to length of longest rod
2. Adjust by moving 3" PVC Pipe upward/ downward, then tighten clamp

Electronic Water Level Management Systems

5 Year Limited Warranty - *WaterLine* Controls®

The 5 Year Limited Warranty is extended to the original consumer purchaser of this *WaterLine* Controls manufactured by *WaterLine* Controls, Scottsdale, Arizona. *WaterLine* Controls warrants the unit, including the parts and components thereof, to be free of defects in material and workmanship under normal use and service conditions. This warranty does not cover plumbing or normal replacement items and parts, including gaskets and O-rings. *WaterLine* Controls does not cover improper installation of the unit or its parts. If you have any questions regarding the installation of your *WaterLine* Controls unit, please feel free to contact us. Be sure to include the serial number of your unit.

The 5 Year Limited Warranty commences on the date of installation. Parts discovered to have manufacturing defects within 1 Year of installation shall be replaced at no charge to the original consumer. Defects discovered after one year and up to the fifth year following the installation, shall be replaced at a fee of \$275.00 per item. *WaterLine* Controls will repair or replace, at its option, a unit or part proved to be defective within the warranty period and under the conditions of this 5 Year Limited Warranty.

This 5 Year Limited Warranty does not apply if the failure is caused or contributed by any of the following: power failure or reduction of power supplied to the unit, unusual atmospheric conditions, improper handling, improper storage, winter freezing, abuse, improper installation, unsuitable application, lack of reasonable and necessary maintenance, natural disasters, or repairs/alterations made or attempted by other than *WaterLine* Controls or an Authorized Technician approved by *WaterLine* Controls.

The consumer must deliver or ship the unit or warranty parts freight prepaid to *WaterLine* Controls. Authorization to return an item to *WaterLine* Controls must be obtained from *WaterLine* Controls Customer Service Department at 888-905-1892. For further assistance with this process please contact the Customer Service Department. Be sure you insure your shipment against loss or damage in transit.

WaterLine Controls is not responsible for the cost of removal of the unit or parts of the unit, damages due to removal, or any other expenses incurred in shipping the unit or parts to or from *WaterLine* Controls or its closest Authorized Service Center or the installation of the repaired or replaced unit. The consumer must bear these expenses.

THIS 5 YEAR LIMITED WARRANTY IS IN LIEU OF ALL OTHER WARRANTIES, EXPRESSED OR IMPLIED, INCLUDING THE IMPLIED WARRANTIES OF MERCHANTABILITY AND FITNESS FOR A PARTICULAR PURPOSE AND ALL SUCH OTHER WARRANTIES ARE DISCLAIMED EXCEPT TO THE EXTENT ANY IMPLIED WARRANTY MAY BE IMPOSED BY STATE CONSUMER LAW. ANY SUCH IMPLIED WARRANTY IMPOSED BY STATE CONSUMER LAW IS LIMITED IN DURATION TO ONE (1) YEAR FROM THE DATE OF INSTALLATION. IN NO EVENT SHALL *WATERLINE* CONTROLS BE LIABLE FOR INCIDENTAL OR CONSEQUENTIAL DAMAGES OR ANY NATURE OR KIND OR FOR DAMAGES TO PERSONS OR PROPERTY, INCLUDING ANY DAMAGE RESULTING FROM THE USE OF THE UNIT WITH A SUBSTANDARD WATER CIRCULATION OR SUPPLY SYSTEM.

Some states do not allow limitations on how long an implied warranty lasts, or the exclusion or limitation of incidental or consequential damages, so the above limitations may not apply to you.

This limited warranty is valid only in the United States of America and Canada.

WaterLine Controls • PO Box 12544 Scottsdale • Arizona 85260

Phone: 888-905-1892 Email: info@waterlinecontrols.com

© SDI 2019