

PUMP I
Relay in the Waterline Unit can be used as Pilot relays to a 110 VAC coil for contactors properly rated for pump operation.

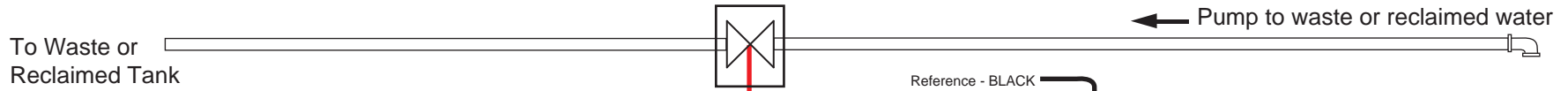

Simplex Pump Down with High Alarm

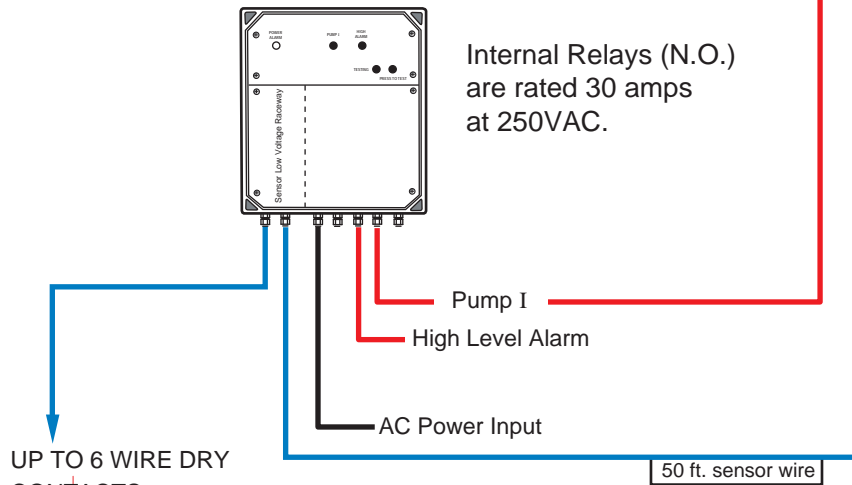

UP TO 6 WIRE DRY CONTACTS TO AUTOMATION SYSTEM - 2 for each function plus 2 for fault conditions. (see truth table for BAS wire quantities)

- * Contact the factory for Custom Sensor requirements.
- * See written specification for more details.

Waterline Controls
P.O. Box 12544 Scottsdale, Arizona 85260
Toll Free: 888-905-1892
Email: info@waterlinecontrols.com • www.waterlinecontrols.com

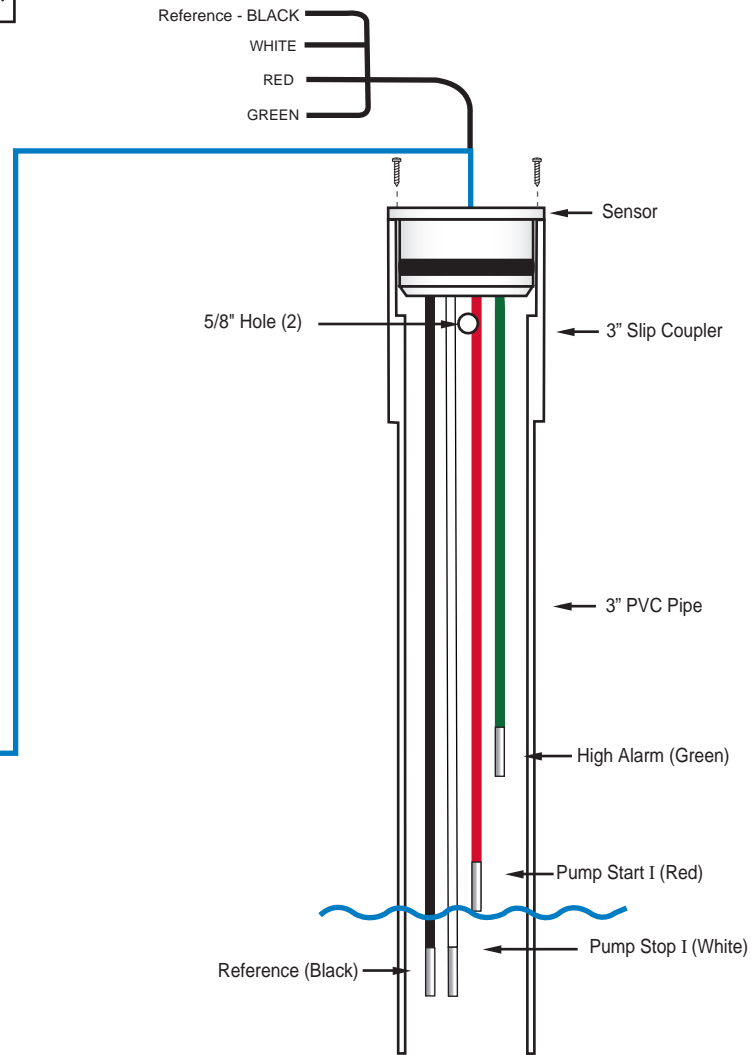

1. The 3" PVC Pipe needs to be at least 2" longer than the longest Sensor tip.
2. Adjustment occurs by moving the 3" PVC Pipe up or down and tightening the clamp so it rests on the Custom Fitting.