

Level Fill Control with Low and High Alarm

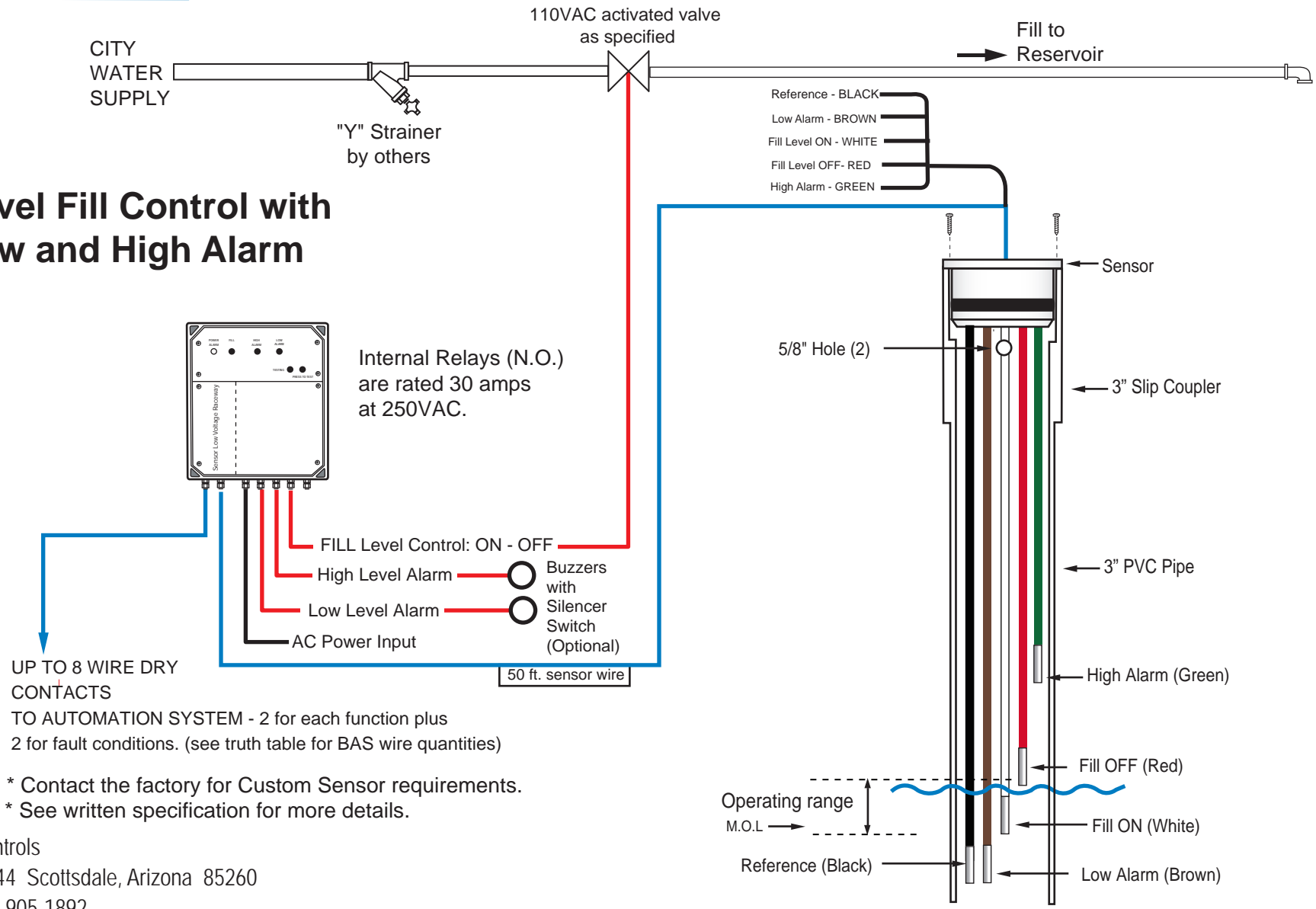

* Contact the factory for Custom Sensor requirements.
 * See written specification for more details.

1. The 3" PVC Pipe needs to be at least 2" longer than the longest Sensor tip.
2. Adjustment occurs by moving the 3" PVC Pipe up or down and tightening the clamp so it rests on the Custom Fitting.