

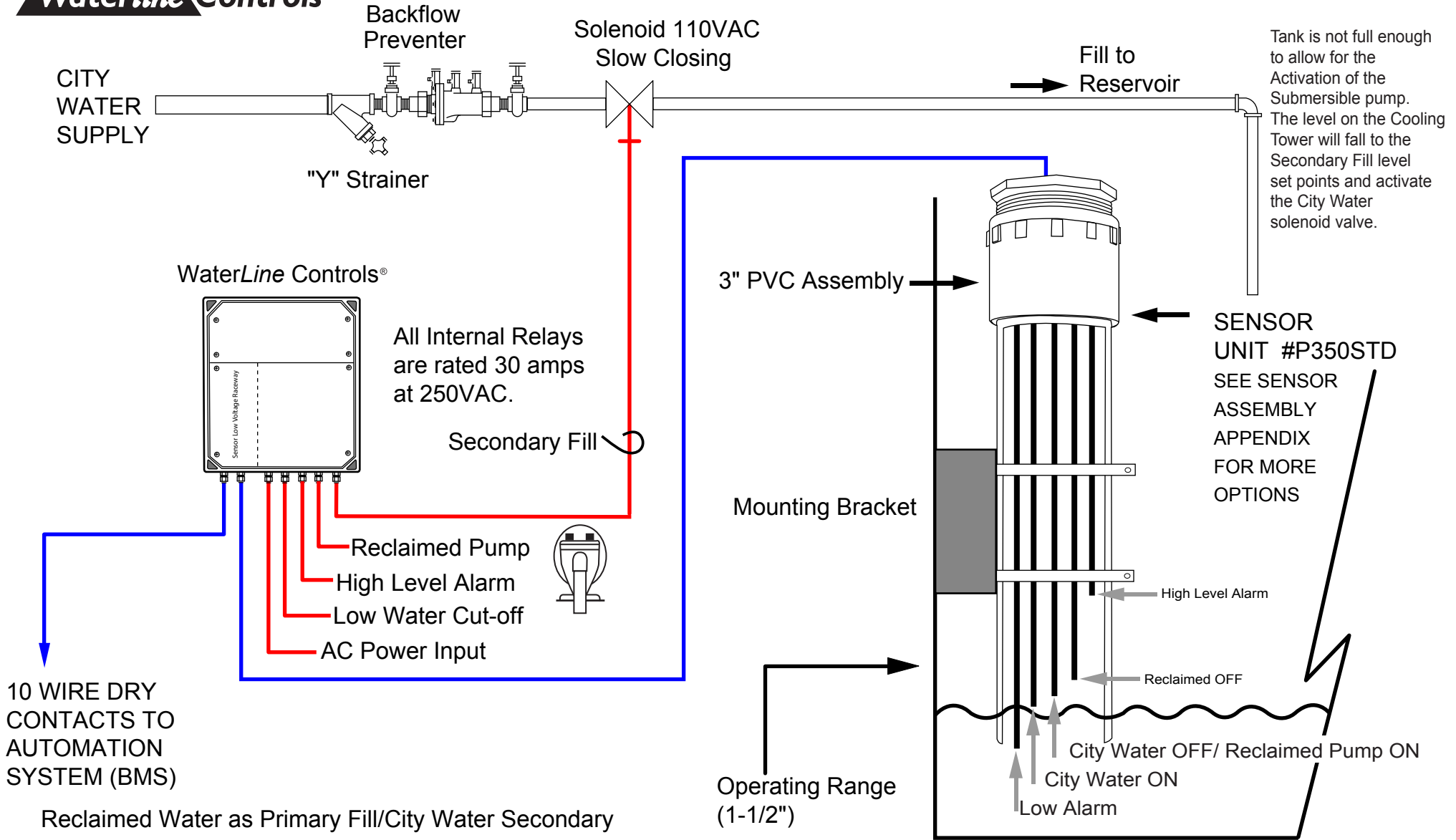

SPECIFICATION FOR WLC-6450

FILL WITH HIGH LEVEL & LOW LEVEL ALARMS



© 2014, SYSTEM DYNAMICS INC.

Blue lines are low voltage Red lines are high voltage		ELECTRONIC LEVEL CONTROL WLC-6450			This document contains information Proprietary and confidential to SYSTEM DYNAMICS INC. It shall not be reproduced, copied or made available to others without prior written consent from SYSTEM DYNAMICS INC.		SYSTEM DYNAMICS, INC. PO Box 12544 Scottsdale, Arizona 85260 1-888-905-1892 www.waterlinecontrols.com		DRAWING NO.	REV.
DATE	REVISION BY	APPROVED:	DWG. REF.:	NOT TO SCALE	S.O. #					
		CHECKED:	DRAWN:	DATE:	P.O. #					SHEET OF