

Dual Fill Control with Low and High Alarm

Internal Relays (N.O.) are rated 30 amps at 250VAC.

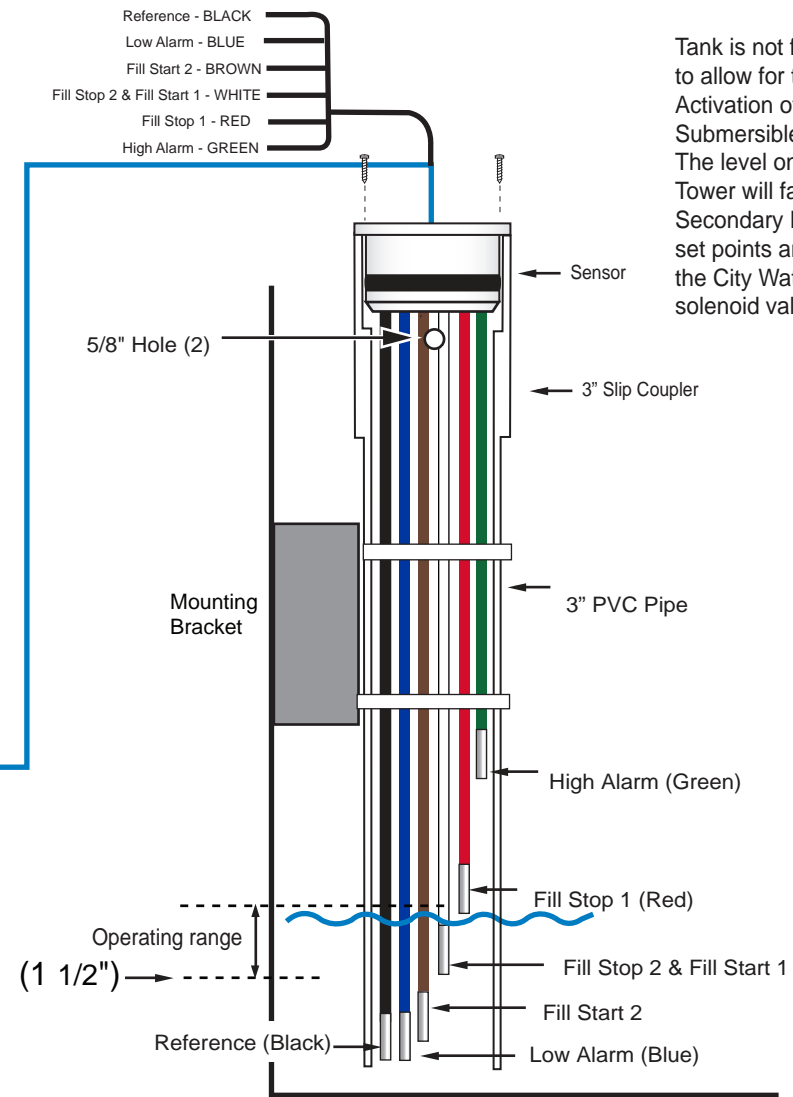
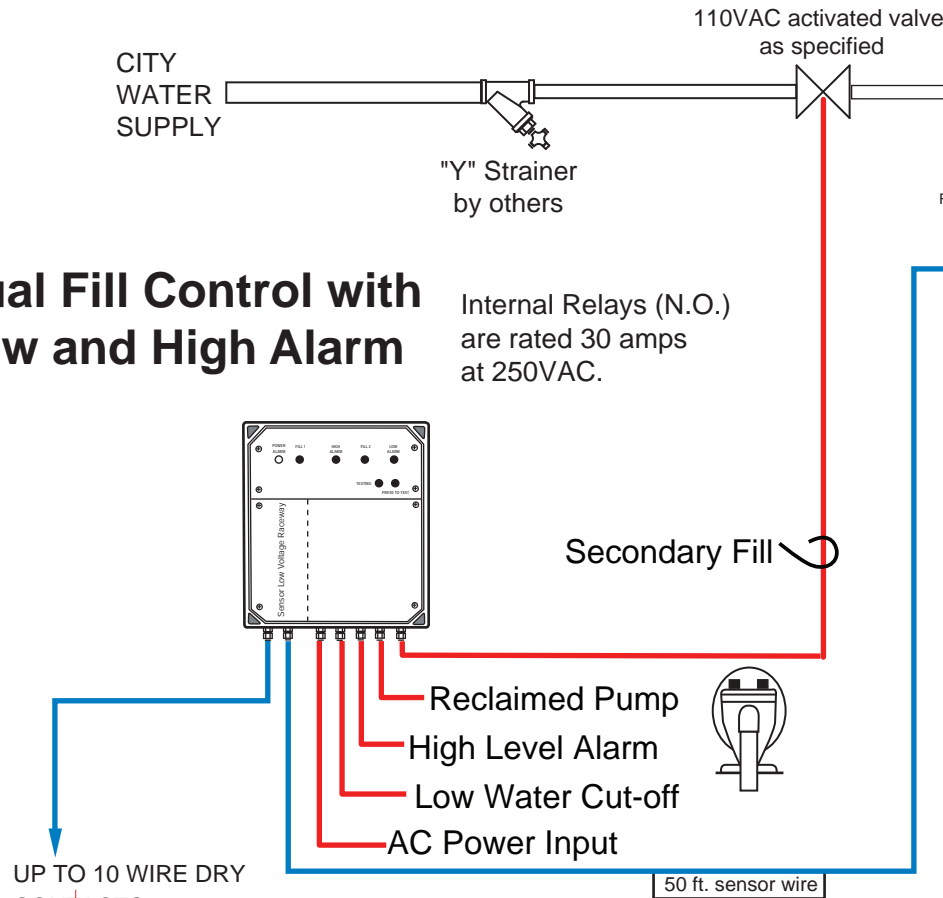

Tank is not full enough to allow for the Activation of the Submersible pump. The level on the Cooling Tower will fall to the Secondary Fill level set points and activate the City Water solenoid valve.

1. The 3" PVC Pipe needs to be at least 2" longer than the longest Sensor tip.
2. Adjustment occurs by moving the 3" PVC Pipe up or down and tightening the clamp so it rests on the Custom Fitting.